

April 1995

CRUISE MISSILES

Proven Capability Should Affect Aircraft and Force Structure Requirements





United States
General Accounting Office
Washington, D.C. 20548

**National Security and
International Affairs Division**

B-256664

April 20, 1995

The Honorable Strom Thurmond
Chairman, Committee on Armed Services
United States Senate

The Honorable Ted Stevens
Chairman, Subcommittee on Defense
Committee on Appropriations
United States Senate

The Honorable Floyd Spence
Chairman, Committee on National Security
House of Representatives

The Honorable C.W. Bill Young
Chairman, Subcommittee on National Security
Committee on Appropriations
House of Representatives

This report, an unclassified version of our August 1994 classified report, discusses the results of our self-initiated review of cruise missiles' wartime performance and potential impact on future aircraft capabilities and forward presence requirements. It contains recommendations to the Secretary of Defense to ensure that the services take cruise missile capabilities into account when determining aircraft requirements and the forces needed for forward presence.

We are sending copies of this report to the Secretaries of Defense, the Air Force, and the Navy and the Director of the Office of Management and Budget.

Please contact me at (202) 512-3504 if you or your staff have any questions concerning this report. Major contributors to this report are listed in appendix II.

A handwritten signature in cursive script that reads 'Richard Davis'.

Richard Davis
Director, National Security
Analysis

Executive Summary

Purpose

Operation Desert Storm marked the first time that U.S. forces employed the Navy's Tomahawk missile and the Air Force's Conventional Air Launched Cruise Missile (CALCM) in combat. GAO initiated this review to determine the missiles' performance during Desert Storm, including any limitations. GAO also addressed the advantages of these missiles over tactical aircraft and the missiles' potential impact on the requirements for future tactical weapon systems and forward presence.

Background

The Tomahawk is a highly accurate subsonic missile powered by a jet engine and is launched from Navy surface ships and submarines. It flies more than 500 miles, navigating along a pre-programmed route that follows specific terrain features to the target. Tomahawk land attack missiles can carry a 1,000-pound class high-explosive or a submunitions warhead. The CALCM is also powered by a jet engine but is launched from B-52 bombers. It flies a pre-programmed route using signals from the Global Positioning Satellite system and carries a conventional blast warhead. The CALCM's accuracy is roughly half that of the Tomahawk. Both weapons are capable of attacking land targets that are fixed or not easily relocatable. A separate variant of the Tomahawk is designed to attack ships at sea.

On January 17, 1991, forces of the U.N.-sponsored coalition initiated a massive aerial campaign against Iraq in response to its August 1990 invasion of Kuwait. U.S. Navy ships and submarines launched 288 Tomahawk missiles and Air Force B-52 bombers launched 35 CALCMs during the campaign, all against targets in Iraq.¹ During the campaign, coalition aircraft launched more than 40,000 individual attacks against targets in Iraq and Kuwait. The targets ranged from strategic facilities, such as electrical generation plants and command and control facilities in Baghdad, to tactical targets, such as deployed Iraqi Army combat units.

Tomahawk missiles have subsequently struck two Iraqi facilities in the Baghdad area. On January 17, 1993, 42 missiles were successfully launched against the Zafraniyah Nuclear Fabrication Facility, and 23 missiles were successfully launched against Iraqi Intelligence Service headquarters on June 26, 1993.

Results in Brief

Military service officials and analysts stated that both the Navy's Tomahawk land attack missile and the Air Force's CALCM contributed to

¹Of the 288 Tomahawks launched, 282 successfully transitioned to cruise flight.

the success of U.S. combat operations during Operation Desert Storm. According to studies conducted by the Center for Naval Analyses and the Defense Intelligence Agency and GAO's analysis of Gulf War Air Power Survey data, Tomahawk missiles and CALCMs hit their intended aim points with success rates approaching those of manned precision strike aircraft, such as the F-117A Stealth Fighter. However, several problems were noted. The Tomahawk demonstrated limitations in its range, mission planning time, and lethality, and the desert terrain made it difficult to employ the Tomahawks. The CALCM's warhead and guidance limited the types of targets it could successfully attack. The Tomahawk's performance improved in subsequent raids on the Zafraniyah nuclear facility and Iraqi intelligence headquarters.² The success rate was about 26 to 35 percent higher for the Zafraniyah raid, and 20 to 29 percent higher for the raid on Iraqi Intelligence Headquarters, than the success rate during Desert Storm. The Navy has funded programs to address the Tomahawk's limitations. The Air Force is studying a proposal to produce two improved variants of the CALCM but, because of competing priorities, has not requested any funds.

As demonstrated during Operation Desert Storm and the two Iraqi raids, cruise missiles have advantages over tactical aircraft systems and provide military commanders additional options for precision strike operations. Cruise missiles can strike many types of targets and can be used in many conditions, such as at night, in a variety of weather conditions, or in heavy air defenses. Cruise missiles can also be used without the additional resources—electronic warfare aircraft, fighter escort, and refueling aircraft—required for manned aircraft strikes. Additionally, as the raid on Iraqi intelligence headquarters demonstrated, such strikes do not require the presence of an aircraft carrier battle group. Employing cruise missiles can also avoid possible political constraints, such as obtaining host nation permission to use U.S. aircraft from forward deployed bases or fly through a third nation's airspace. Most importantly, cruise missiles provide the ability to strike targets without risking the loss of aircraft and the death or capture of U.S. aircrew members. However, tactical aircraft systems have some advantages over cruise missiles, including their ability to attack mobile or relocatable targets and penetrate more hardened targets, and will therefore retain a key role in offensive air operations. Also, aircraft-delivered munitions are better suited for conducting large-scale or extended campaigns because of their relatively lower costs.

²CALCMs were not used in these strikes.

Since the Tomahawk and CALCM have broadened the options available to commanders and can be used against many categories of targets struck by manned aircraft, the characteristics (such as range and degree of stealth) of most aircraft and the number of aircraft required for future precision strike weapon systems should be affected. In addition, since Navy warships carrying cruise missiles have shown that they can conduct forward presence missions and crisis response without the presence of carrier-based air forces, they are a viable option for performing those missions. As a result, fewer aircraft carriers may be required, which could result in budgetary savings.

Principal Findings

Tomahawk and CALCM Contributed to Success of Desert Storm

Both the Tomahawk and the CALCM contributed to the success of recent U.S. combat operations. According to studies conducted by the Center for Naval Analyses and the Defense Intelligence Agency and GAO's analysis of Gulf War Air Power Survey data, the percentage of Tomahawks and CALCMS fired during Operation Desert Storm that struck their intended aim points approached the rate at which bombs carried aboard F-117As on strike missions hit their intended targets. The Tomahawk missiles were able to strike heavily defended targets that, if attacked by aircraft, could have resulted in the unacceptable loss of aircraft and aircrews. For example, Tomahawk missiles were the only weapons used against targets in the downtown Baghdad area during daylight for most of the campaign. In addition, cruise missiles were used in attacks against 8 of the 12 categories of targets struck by manned aircraft.

Desert Storm also demonstrated several limitations in the design and employment of both missiles. Tomahawk operations were hampered by the lengthy mission planning process and the stringent geographic information requirements to support the missile's navigation systems. Also, the desert terrain made it difficult to employ the Tomahawks.

Improvements already incorporated into the Tomahawk weapon system since the Persian Gulf War address many of the limitations noted during Operation Desert Storm. Table 1 summarizes the Tomahawk limitations that were noted during Desert Storm and subsequent improvements incorporated into the missile.

Table 1: Tomahawk Limitations and Improvements

Limitation	Improvement	Result
Tomahawk was not responsive to the tactical commander's needs, since route selections were limited, mission planning times were lengthy, and its arrival with tactical aircraft was difficult to coordinate accurately.	Global Positioning System guidance was added, mission planning hardware and software were upgraded and automated, Afloat Planning System was introduced, and Time of Arrival software was incorporated.	Route selections are expanded. Mission planning time is reduced by about 90 percent. Theater commanders will have an in-theater mission planning capability. The Time of Arrival software allows strike times to be coordinated much more accurately.
Unitary warhead's penetrating ability was limited.	Warhead was redesigned and programmable delay fuse was incorporated.	Lethality is increased because the missile can penetrate further into targets before the warhead detonates.
Some targets were at the extreme limit of the missiles' range.	Warhead and engine were redesigned.	The new, lighter warhead allows the missile to carry more fuel, extending the range. The redesigned engine provides more thrust and is more fuel efficient.
Stream raids alerted Iraqi defenses.	Global Positioning System guidance was added.	Since more routes to the targets will be available, defenders will not be alerted by the repetitive use of a few routes.

Additional improvements to the missile are under consideration that if incorporated, would further extend the Tomahawk's capability. The missile's accuracy would be increased by about 60 percent, the warhead's penetration ability would be increased by about 100 percent, and the same missile variant would be able to attack both surface ships and land targets. Additionally, both the time required for the mission planning process and the information required to support that process would be reduced to levels commensurate to that required for manned aircraft strikes.

The Tomahawk was also employed subsequent to Operation Desert Storm in strikes against two targets in the Baghdad area. The Tomahawks were used for both strikes instead of manned aircraft because the National Command Authorities (i.e., the President and the Secretary of Defense) were unwilling to risk the loss of aircraft or aircrews. In January 1993, Navy ships in the Red Sea and the Persian Gulf launched 42 missiles against the Zafraniyah nuclear facility, and in June 1993, 23 missiles were launched against Iraqi Intelligence Service headquarters. The Tomahawk's success in striking its intended aimpoint increased by about 26 to

35 percent, and 20 to 29 percent, respectively, from the Desert Storm success rates. These missiles were the same model as those used in Desert Storm.

The CALCM's employment during Operation Desert Storm was limited due to the nature of its warhead and guidance system. The warhead's limited ability to penetrate targets and the guidance system's lower accuracy (compared with the Tomahawk's) restricted the types of targets that could be successfully attacked. Even though the Air Force is studying a proposal to upgrade the CALCM, it has not funded any improvements to the missile to address the limitations identified in Desert Storm due to competing funding priorities.

Cruise Missiles Broaden Combat Options

Cruise missiles have some advantages over tactical aircraft systems. For example, with a destructive capability generally similar to that of aircraft-delivered munitions of the same class, Tomahawk missiles allow U.S. forces to strike an adversary's fixed targets with precision at long ranges without risking the loss of aircraft or aircrews. This capability is advantageous when responding to a crisis or in the early stages of an extended campaign when an adversary's air defenses would normally be their strongest. Currently, 135 ships and submarines are equipped to launch Tomahawk missiles, which significantly expands the U.S. ability to respond to an adversary. Also, as demonstrated by the June 1993 strike against Iraq, the Tomahawk allows U.S. forces to take offensive action without the presence of an aircraft carrier battle group or the tasking of conventional air forces. The CALCM can also be launched for attack with no U.S. forces present in theater. For example, the B-52 bombers that launched CALCMS during Desert Storm took off from an air base in the United States. In addition, the submarine-launched Tomahawk introduces an element of surprise.

Cruise missiles do not require the support of as many assets as are needed for manned air strikes. The missiles are only dependent on the platforms from which they are launched, whereas manned aircraft require support from tanker aircraft, electronic jammer, or fighter aircraft. In addition, some political constraints may be avoided by employing the Tomahawk rather than tactical aircraft. For example, since the Tomahawk is a seaborne weapon system, the need to obtain prior base access or overflight agreements is minimized.

Tactical aircraft systems have some advantages over cruise missiles and will therefore retain a key role in air operations against enemy targets. Tactical aircraft are better suited for conducting large-scale or extended campaigns. Because of aircraft-carried munitions relatively lower cost (e.g., a 2,000-pound laser-guided bomb, can cost about \$60,000 compared with \$1.1 million for a Tomahawk missile) and greater inventory, the numerous targets in such campaigns would be more effectively attacked by aircraft-carried munitions. Furthermore, cruise missiles must be programmed with the target's location before being launched. Therefore, only manned aircraft currently have the flexibility to successfully attack mobile or easily relocatable targets, such as tanks and other ground forces.

Cruise Missile Capabilities Should Affect Future Aircraft and Carrier Requirements

Cruise missile capabilities should affect the requirements for most future precision strike weapon systems, since the missiles have broadened the combat options available and can strike heavily defended and longer range targets with results, in many cases, similar to those of manned aircraft attacks. Therefore, most future strike aircraft, if employed in conjunction with cruise missiles and a limited number of highly capable aircraft, may not require as long a range or as high a degree of stealth as originally planned. In addition, fewer strike, tanker, command and control, and electronic warfare aircraft may be required if cruise missiles are used to strike a larger portion of enemy targets.

According to Department of Defense (DOD) directives, an important objective of the defense acquisition system should be to minimize the overlap and duplication among weapon systems. However, GAO has previously reported that the services justify acquisitions of new systems on narrowly defined tasks or on a unique weapon system capability because the services believe they have specific, but complementary, requirements for engaging similar targets. As a result, alternative systems are not always considered. For example, in July 1993, GAO reported that an analysis of theater air interdiction by the Chairman of the Joint Chiefs of Staff considered only fixed-wing aircraft and did not consider options for using land- or sea-based missiles and long-range artillery.³ Also, in April 1992, GAO reported that the Air Force and the Army limited their analyses of close air support requirements to the types of weapons

³Roles and Functions: Assessment of the Chairman of the Joint Chiefs of Staff (GAO/NSIAD-92-200, July 15, 1993).

currently under their respective purview and gave little, if any, consideration to the contributions of other close support weapons.⁴

Both the Navy and the Air Force have tactical aircraft upgrade programs underway that will require major expenditures. These programs will result in modifying existing aircraft to enhance their strike capabilities, developing new aircraft, and retiring some aircraft types. For example, the Navy is developing the F/A-18 E/F, which it expects will be its primary carrier-based attack aircraft, at an estimated total cost of about \$85 billion for 1,000 aircraft. The Navy is also modifying the F-14 to provide it with a strike capability and is planning to retire all its A-6 medium strike bombers, its only carrier-based, long-range, all-weather strike aircraft. Additionally, the Air Force plans to incorporate a ground attack capability into the F-22.

As demonstrated by the June 1993 raid on Iraq, cruise missiles provide the United States with a viable strike capability in the absence of aircraft carrier-based strike aircraft. DOD's Bottom-Up Review stated that only 10 carriers were required for conducting two nearly simultaneous major regional contingencies but that 11 were required to meet forward presence requirements in three worldwide regions. The review noted that the planned aircraft carrier force level of 11 active carriers and 1 training carrier would support regional forward presence 12 months per year in one region but would result in an average 4-month gap in carrier presence per year for the two remaining regions. The review also stated that 10 carriers would increase the average gap in carrier presence in the two regions to 6 months. The review depicted a 4-month gap as an acceptable risk and a 6-month gap as unacceptable.

If the Tomahawk-capable warships were judged to be an acceptable alternative for conducting presence operations, the Navy could achieve considerable budgetary savings. GAO previously reported that the average annualized cost of a notional aircraft carrier battle group was \$1.5 billion.⁵

Recommendations

GAO recommends that the Secretary of Defense assess the extent to which cruise missiles could affect the requirements for manned strike aircraft and aircraft carriers. This assessment should examine the (1) effect that

⁴Major Acquisition: DOD's Process Does Not Ensure Proper Weapons Mix for Close Support Mission (GAO/NSIAD-92-180, Apr. 17, 1992).

⁵Navy Carrier Battle Groups: The Structure and Affordability of the Future Force (GAO/NSIAD-93-74, Feb. 25, 1993).

existing cruise missiles and potential upgrades have on the design characteristics, such as the range, payload, and stealth characteristics, of planned future aircraft; (2) potential effect of the resulting alternative aircraft designs on future aircraft affordability; and (3) degree to which increased cruise missile inventories could affect the number of aircraft to be procured. GAO also recommends that the Secretary of Defense reassess the degree to which cruise missile-equipped platforms could fulfill peacetime presence requirements and the effect that increased reliance on those platforms would have on the Bottom-Up Review's justification for an additional aircraft carrier for presence missions.

Agency Comments

DOD provided written classified comments on the classified draft of this report. DOD partially concurred with the major findings of that report, but it disagreed with GAO's recommendations. GAO has incorporated unclassified summaries of DOD's comments in this report where appropriate.

DOD agreed that cruise missiles provided many useful capabilities and that new generations should be more flexible and versatile than existing missiles. However, DOD said that cruise missiles had inherent limitations that precluded them from successfully performing some strike missions; therefore, even though cruise missiles represent an important supplement to U.S. air power, they cannot replace manned aircraft. It also said that the Bottom-Up Review process took into account the capabilities of cruise missiles and other advanced munitions when it set its force goals and modernization priorities.

Although DOD said it considered cruise missile capabilities as part of the Bottom-Up Review process, GAO found no analysis that specifically made the assessments it recommended. DOD did not provide any documentation to support its statement that cruise missile contributions were considered.

GAO agrees that cruise missiles do not provide the full range of capabilities inherent in an aircraft carrier battle group, either from the standpoint of providing peacetime presence or responding to a crisis. However, GAO believes that not all situations require the full capability of an aircraft carrier battle group to show U.S. resolve and commitment or forestall actions by other nations. Therefore, although cruise missiles may not address all peacetime presence situations, GAO still believes that cruise missiles provide useful options for conducting some peacetime presence missions and that its recommendation is valid.

Contents

Executive Summary		2
Chapter 1		12
Introduction	The Tomahawk Weapon System	12
	CALCM	17
	Objectives, Scope, and Methodology	18
Chapter 2		21
Cruise Missiles’ Capabilities Have Been Proven in Recent Conflicts	The Desert Storm Air Campaign	22
	Cruise Missiles’ Performance in Desert Storm	24
	Tomahawk Performance Since Desert Storm	27
	Tomahawk Improvements to Address Shortfalls and Expand Capabilities	28
	Agency Comments and Our Evaluation	30
Chapter 3		33
Cruise Missiles Broaden Options	Cruise Missiles Offer Additional Options for Attacking Targets	33
	Tactical Aircraft Systems Retain Key Roles	39
	Agency Comments and Our Evaluation	41
Chapter 4		43
Cruise Missiles’ Proven Capabilities Should Affect Strike Aircraft Requirements and Force Structure Choices	Cruise Missiles Can Affect Strike Aircraft Requirements	43
	Services Do Not Always Consider Alternatives	45
	Cruise Missile-Equipped Platforms Can Provide Forward Presence and Crisis Response	46
	Recommendations	47
	Agency Comments and Our Evaluation	47
Appendixes	Appendix I: Tomahawk Improvements Address Limitations	50
	Appendix II: Major Contributors to This Report	60
Tables	Table 1: Tomahawk Limitations and Improvements	5
	Table 1.1: Tomahawk-Capable Naval Forces Projected for 1999	16
	Table 2.1: Block III Tomahawk Improvements That Address Desert Storm Limitations	29
	Table 2.2: Tomahawk Block IV Improvements Over Block III	30
	Table 3.1: Comparison of Tomahawk and Manned Aircraft	34

Table 3.2: Representative Navy Strike Packages in Desert Storm	37
--	----

Figures

Figure 1.1: Tomahawk Missile Variants	13
Figure 1.2: Block II Tomahawk Flight Profile	15
Figure 2.1: Desert Storm Area of Operation	23
Figure I.1: Block III Navigation Modes	52
Figure I.2: World Areas Covered by the Block II and Block III TLAM-C Missiles' Range	55
Figure I.3: Block IV Concept of Operations	59

Abbreviations

APS	Afloat Planning System
CALCM	Conventional Air Launched Cruise Missile
CEP	Circular Error Probable
CMSA	Cruise Missile Support Activity
CNA	Center for Naval Analyses
DIA	Defense Intelligence Agency
DOD	Department of Defense
DSMAC	digital scene mapping and area correlation
GAO	General Accounting Office
GPS	Global Positioning System
HARM	High Speed Anti-radiation Missile
TERCOM	terrain contour matching
TASM	Tomahawk Antiship Missile
TLAM	Tomahawk Land Attack Missile

Introduction

Operation Desert Storm marked the first time that the Navy's Tomahawk Land Attack Missile and the Air Force's Conventional Air Launched Cruise Missile (CALCM) were used in combat. A total of 323 cruise missiles were fired against a variety of Iraqi targets in the conflict's early stages. The missile attacks were part of a multiphase air campaign designed to decapitate the Iraqi leadership, gain air superiority, and reduce Iraqi combat power in preparation for the ground offensive to restore Kuwait's border. Tomahawk missiles have subsequently struck two Iraqi facilities in the Baghdad area. U.S. ships launched 42 missiles against the Zafraniyah Nuclear Fabrication Facility on January 17, 1993, and 23 missiles against Iraqi Intelligence Service headquarters on June 26, 1993. These attacks demonstrated that cruise missiles could play an important role in both major conflicts and more limited engagements by allowing U.S. forces to strike an adversary with a high degree of accuracy at long ranges and without risking the loss of aircraft or aircrew.

The Tomahawk Weapon System

The Tomahawk cruise missile is a long-range, unmanned subsonic missile with both land attack and antiship capability that can be employed under a variety of weather conditions. It is launched from a variety of Navy surface ships and attack submarines. There are four Tomahawk variants: the nuclear land attack missile (TLAM-N), the antiship missile (TASM), the conventional land attack missile with a unitary warhead (TLAM-C), and the conventional land attack missile with a submunition warhead (TLAM-D). Each variant employs a common body and propulsion system but is equipped with different warheads and guidance systems. The four variants are shown in figure 1.1.

Figure 1.1: Tomahawk Missile Variants

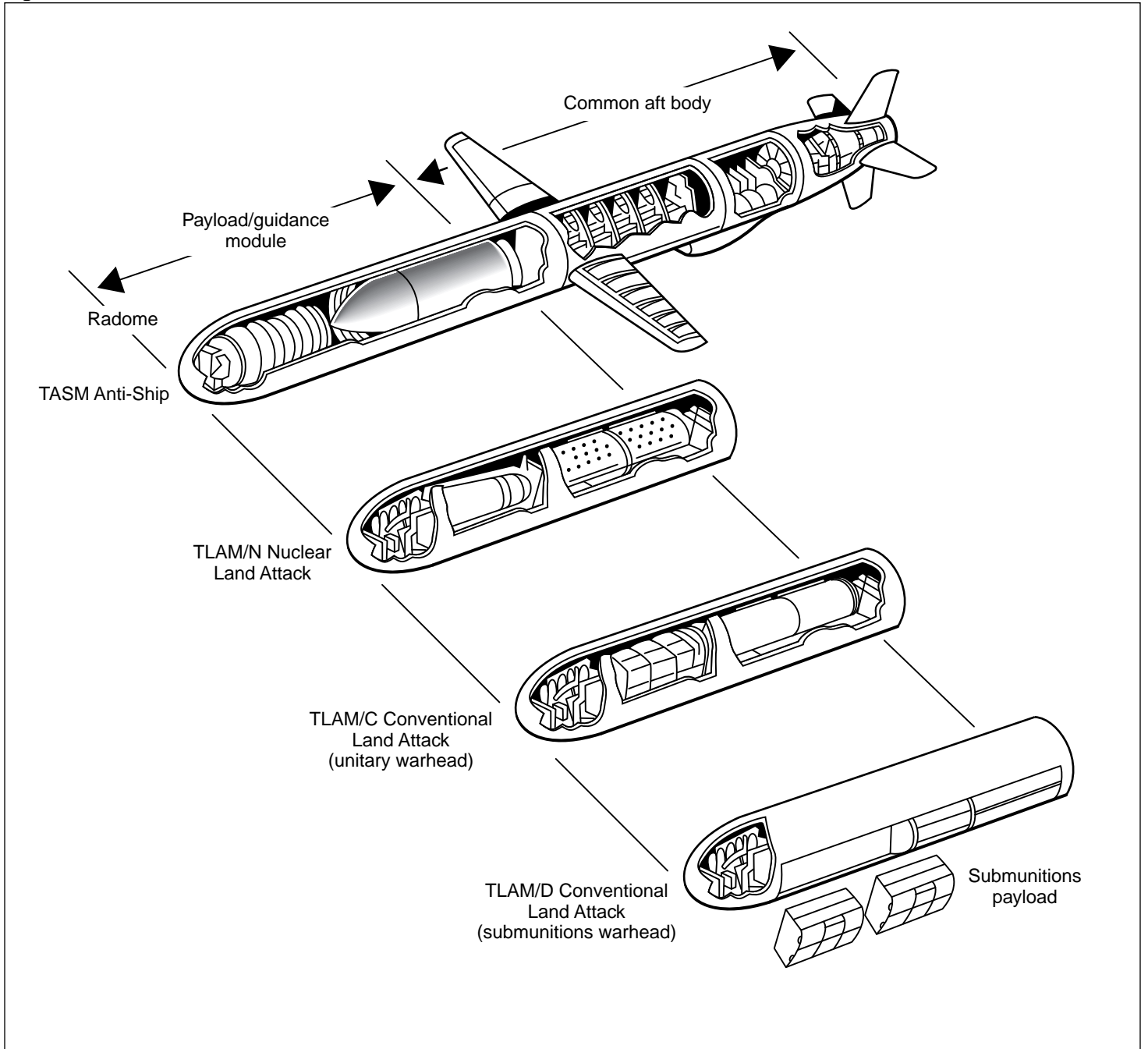

Source: Navy.

Navy ships and submarines currently deploy predominantly with TLAM-CS and TLAM-DS. The TLAM-NS were removed from the vessels as the Cold War was ending. Navy officials said that the TASM's mission has been reduced because this variant is not particularly suited to warfare in littoral waters that may be crowded with both combatant and noncombatant ships. The TASM was originally intended as an over-the-horizon, open ocean, antiship weapon to be employed against ships in a battle group.

The TLAM-CS and -DS employed during Operation Desert Storm and the subsequent strikes were Block II missiles, which make up the majority of the current inventory.¹ All Tomahawks delivered to the Navy since April 1993 have been improved Block III models. The Navy plans production of a Block IV variant by the end of this decade. The improvements incorporated in the Block III missile and those planned for Block IV are discussed in appendix I.

The Block II Missile

The principal difference between the Block II TLAM-C and TLAM-D is the warhead. The TLAM-C carries a 1,000-pound-class unitary warhead, and the TLAM-D carries a submunitions payload consisting of 166 bomblets. The TLAM-C is employed against a single fixed target, such as a specific point on a building, whereas the TLAM-D is designed to attack area-type targets, such as aircraft parked on a ramp. A single TLAM-D missile can dispense its submunitions payload over as many as three separate targets.

The Block II TLAM-C and TLAM-D ranges equal or exceed the unrefueled combat radius of most U.S. manned tactical strike aircraft. However, those missiles that are launched from a submarine torpedo tube have a range about 30 percent less than surface ship-launched missiles. The submarine-launched Tomahawk has a booster rocket that propels the missile to the surface after it leaves the torpedo tube. The missile is partially de-fueled to compensate for the booster's added weight, which decreases its range. However, the Navy has begun procuring an improved booster that allows submarines to launch fully fueled missiles.

The Tomahawk missile follows a pre-programmed route over specific terrain features to its target using a combination of terrain contour matching (TERCOM) and digital scene matching and area correlation (DSMAC). The Tomahawk's flight profile is illustrated in figure 1.2.

¹A block represents an overall baseline for the missile system's configuration.

Figure 1.2: Block II Tomahawk Flight Profile

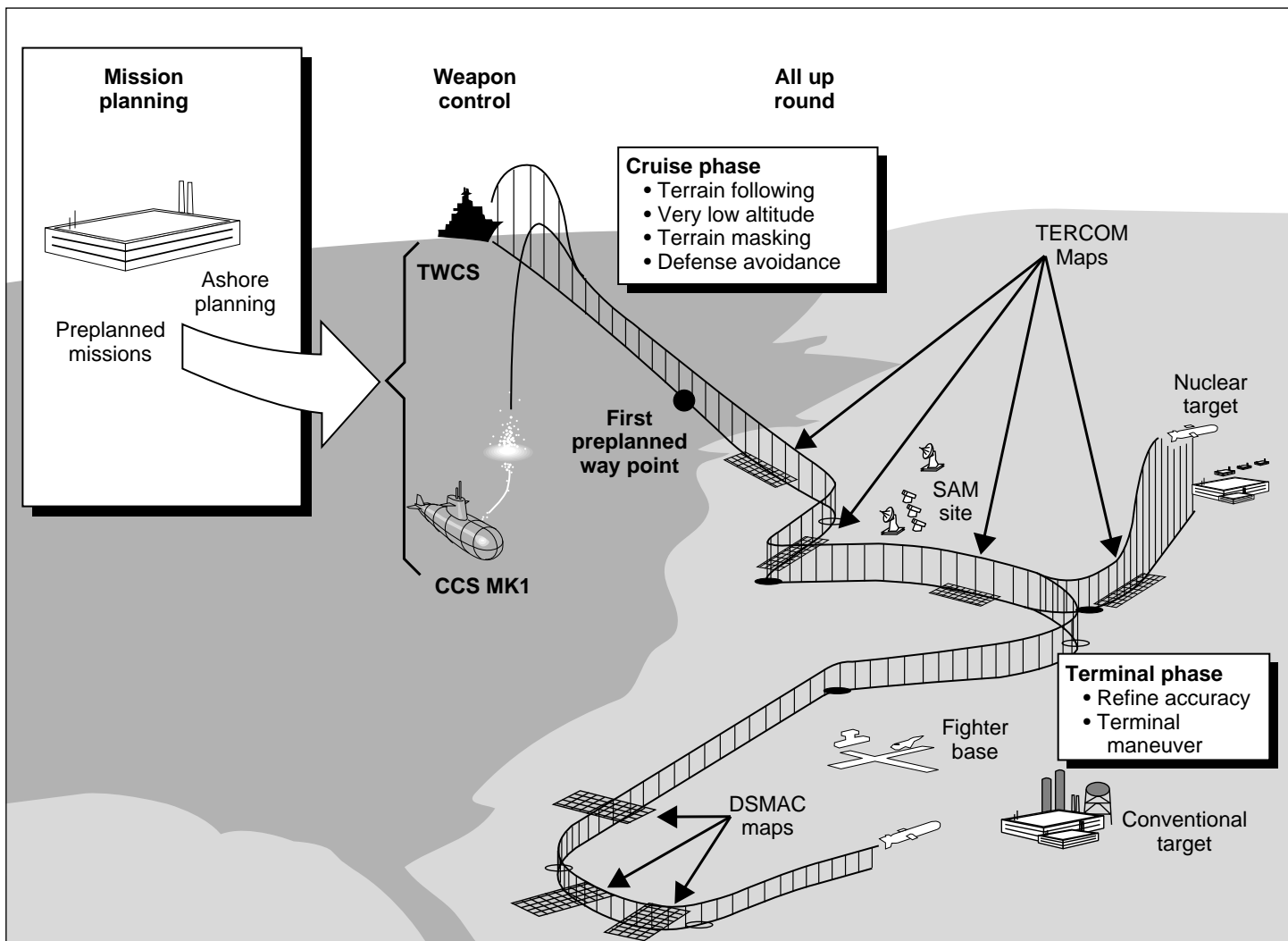

Note: CCS MK1, Combat Control System Mark 1; SAM, surface-to-air missile; TWCS, Tomahawk Weapon Control System. An all up round is a complete missile assembly.

Source: Navy.

During the initial portion of its flight, the missile navigates by TERCOM. A radar altimeter aboard the missile periodically scans the terrain over

which the missile is flying. The on-board computer then compares the resulting terrain elevation profile to its profile of the predicted route to the target, which was stored in the computer before the missile's launch. The computer then adjusts the missile's course so that it is following the planned route to the target.

The Tomahawk navigates by DSMAC during the terminal leg of its flight to the target. The DSMAC process uses an optical sensor in the missile that scans the ground over which the missile is flying. The on-board computer converts the scanned image of the ground features into an image of black and white contrasts. The computer then compares that image to its stored DSMAC black and white images of the selected sites along the route. As with TERCOM, the missile's computer then adjusts the missile's course so it is following the preplanned route. The Block II missile uses inertial navigation between TERCOM and DSMAC update points.

Currently, 60 surface ships and 75 submarines are capable of launching Tomahawk missiles. The Navy projects that by 1999 the Tomahawk-capable force will consist of 82 ships and 55 submarines. Table 1.1 shows the projected Tomahawk platform force.

Table 1.1: Tomahawk-Capable Naval Forces Projected for 1999

Class	Ship				Submarine class				Total
	CG	DD-963	DD-963	DDG-51	SSN-688	SSN-688	SSN-637	SSN-21	
Launch system	VLS ^a	VLS	ABL ^b	VLS	CLS ^c	TTL ^d	TTL	TTL	
Number of assets	22	24	6	30	31	20	1	3	137

Note: All Tomahawk-capable platforms are equipped to launch both Block II and Block III missiles, and the Block IV missile is planned to be compatible with any Tomahawk-capable ship or submarine.

^aVLS stands for vertical launch system. It is the missile launch system carried aboard many surface combatants and is capable of launching anti-air missiles in addition to the Tomahawk. VLS can hold either 61, 90, or 122 missiles, depending on ship type.

^bABL stands for armored box launcher. It is a Tomahawk launch system installed aboard some surface ships not equipped with VLS and can hold up to four Tomahawks.

^cCLS stands for capsule launch system. It is a submarine-based version of VLS.

^dTTL is the torpedo tube launch system. All SSN-688, -637, and -21 class submarines can launch the Tomahawk from their torpedo tubes.

The planned wartime loads of TLAM-C and TLAM-D missiles vary for surface ships and submarines. Navy officials said that notional missile loads are

used for planning purposes; actual loads could vary depending on the specific mission assigned by the operational commander.

The Tomahawks share launcher space with other missiles on several ship classes. Arleigh Burke class destroyers and Ticonderoga class cruisers are predominantly loaded with standard surface-to-air missiles. Because attack submarines have limited weapon storage space, all TTL Tomahawks carried displace an equal number of torpedoes.

Tomahawk Procurement

The Navy plans to continue procuring Block III TLAM-C missiles until fiscal year 1998. It plans to procure 216 missiles in fiscal year 1994 at a cost of about \$1.2 million per missile and 217 missiles per year from fiscal years 1995 to 1998. The Navy currently plans to begin production of the Block IV missile through the remanufacture of existing Block II missiles and TASMS after fiscal year 1998.

CALCM

The Air Force's CALCM was the other U.S. cruise missile used in the Gulf War. The CALCM is a modification of the nuclear-armed Air Launched Cruise Missile, which is a subsonic, all-weather cruise missile. During the modification process, certain components are removed, and a conventional warhead is installed. A Global Positioning System navigation capability is also added. The resulting weapon has a circular error probable (CEP) roughly twice that of the Block III TLAM-C.²

The CALCM is carried by B-52 bombers and is launched within range of the target. After launch, CALCM follows a preplanned route to its target, using inertial navigation with Global Positioning System updates. The missile's mission can be changed or updated by the flight crew while the B-52 is airborne. New or updated missions can be transmitted to the aircraft from the air base and then loaded into the missile's computer. This process allows CALCM missions to be changed or updated any number of times before launch. However, once launched, no communications with the missile are possible. The Air Force's current inventory of CALCM's includes missiles authorized to replace those used in Desert Storm.

Mission planning for the CALCM is performed at Offutt Air Force Base, Nebraska. The average mission planning time for a new target for CALCM is comparable to the planning time for a Block II Tomahawk mission. The completed missions are transmitted to a U.S. air base from which the B-52

²CEP denotes the radius around the target in which 50 percent of the missiles can be expected to land.

CALCM flight will be launched. Bomber preparation and loading can take an average of 24 hours but can be done concurrently with mission planning. Flight times to Iraq during Desert Storm averaged 16 hours. Total response time for CALCM for an unplanned target in Iraq is similar to that of the Block II Tomahawk.

Objectives, Scope, and Methodology

We initiated this review because Desert Storm and subsequent Iraqi strikes showed that the Tomahawk and CALCM added a new dimension to offensive air operations. We determined the missiles' performance during Desert Storm, including any limitations. We also addressed the advantages of these missiles over tactical aircraft and the missiles' potential impact on the requirements for future tactical weapon systems and forward presence.

We met with agency officials responsible for program management and obtained pertinent documents concerning the characteristics, missions, and employment concepts of the Tomahawk cruise missile system and several tactical aircraft systems capable of striking the same types of targets as the Tomahawk. We also obtained information on future planned aircraft and missile systems and planned modifications to existing systems.

To gain the operators' perspective on the Tomahawk, CALCM, other unmanned standoff weapons, and manned aircraft, we met with officials of two unified commands and various Navy and Air Force commands. During those visits, we discussed the commands' policies and procedures for employing Tomahawk and various precision strike systems. We also visited two Tomahawk-capable ships—the U.S.S. Stump, a Spruance class destroyer, and the U.S.S. Key West, a Los Angeles class attack submarine—and discussed Tomahawk operations with the officers and crews of those vessels. Additionally, we visited the Navy's Strike Warfare Center and discussed the planning and conduct of carrier strike operations with officials of the Center.

To gain insights into the roles and experiences of the various weapons systems in the Gulf War, we interviewed Navy and Air Force officers who participated in Tomahawk and CALCM planning and employment during the Gulf War and the two subsequent Tomahawk strikes on Iraq. We also met with officials who had analyzed the planning and preparation that preceded the air campaign and the campaign's results. Additionally, we reviewed various studies and reports concerning the campaign, including

the major reports directed by the Navy and the Joint Chiefs of Staff on the performance of Tomahawk in Desert Storm and the two 1993 raids on Iraq.

We analyzed data from the Air Force-sponsored Gulf War Air Power Survey and met with officials who performed this survey to develop information concerning the number and types of targets attacked and the aircraft and missile systems used to conduct those attacks. We limited our analysis to the Tomahawk and CALCM missiles and precision strike systems and the targets they attacked. At our request, Navy and Air Force officials performed several analyses that compared the effectiveness of various weapon systems against a selected group of targets.

We performed our work at the following locations:

In the Washington D.C., area

- Office of the Secretary of Defense
- Office of the Chairman, Joint Chiefs of Staff
- Office of the Chief of Naval Operations
- Headquarters, U.S. Air Force
- Cruise Missile Project Office
- Defense Intelligence Agency
- Naval Research Laboratory
- Advanced Research Project Agency
- Naval Maritime Intelligence Center
- Center for Naval Analysis
- Institute for Defense Analysis
- Center for Air Force History

In the Norfolk, Virginia, area

- Headquarters, U.S. Atlantic Fleet
- Cruise Missile Support Activity, Atlantic
- Operational Test and Evaluation Force
- U.S.S. Stump
- U.S.S. Key West
- Air Combat Command

In the Honolulu, Hawaii, area

- Headquarters, U.S. Pacific Command
- Headquarters, U.S. Pacific Air Forces

- Headquarters, U.S. Pacific Fleet
- Cruise Missile Support Activity, Pacific

At MacDill Air Force Base, Florida

- Headquarters, U.S. Central Command
- Headquarters, Navy Central Command

Other U.S. Locations

- Naval Strike Warfare Center, Naval Air Station, Fallon, Nevada
- Headquarters, Central Air Forces, Shaw Air Force Base, Sumter, South Carolina

We performed our work from August 1992 to December 1993 in accordance with generally accepted government auditing standards. The Department of Defense (DOD) provided written classified comments on a classified draft of this report. DOD partially concurred with the major findings of the report, but it disagreed with our recommendations. Unclassified summaries of DOD's comments have been included in the report where appropriate.

Cruise Missiles' Capabilities Have Been Proven in Recent Conflicts

Both the Tomahawk and the CALCM contributed to the success of U.S. combat operations during Desert Storm and the 1993 strikes on Iraq. During Desert Storm, U.S. Navy ships and submarines launched 288 Tomahawk missiles, and Air Force B-52 bombers launched 35 CALCMs, all against targets in Iraq. The missiles were used against a wide range of targets that included predominately electrical production facilities; Scud missile facilities; command, control, and communications facilities; and leadership targets. Many of these targets were similar to those attacked by manned aircraft. Cruise missiles struck fixed, heavily defended strategic targets that if attacked by manned aircraft—particularly non-stealth aircraft—could have resulted in the unacceptable loss of aircrews and aircraft. The cruise missiles also struck targets at ranges that would have required manned strike aircraft to refuel.

According to studies conducted by the Center for Naval Analyses and the Defense Intelligence Agency, Tomahawk missiles and CALCMs hit their intended aim points with success rates approaching those of manned precision-strike aircraft, such as the F-117A stealth fighter. The Tomahawk's performance improved in the 1993 raids on the Zafraniyah nuclear facility and Iraqi intelligence headquarters. The success rate was about 26 to 35 percent higher for the Zafraniyah raid, and 20 to 29 percent higher for the raid on Iraqi Intelligence Headquarters, than the Tomahawk's success rate during Desert Storm.

Desert Storm also demonstrated several limitations in the design and employment of both missiles. Tomahawk operations were hampered by the stringent geographic information requirements to support the missile's navigation systems and the lengthy mission planning process. The Tomahawk also demonstrated limitations in its range and lethality. The limited ability of the CALCM's warhead and its guidance system's lower accuracy (compared with the Tomahawk's) restricted the types of targets that the CALCM could successfully attack.

Improvements have already been incorporated into the Block III Tomahawk variant currently in production and address many of the limitations noted during Operation Desert Storm. The proposed Block IV Tomahawk would further expand the missile's capabilities. The Air Force is studying a proposal to produce two improved variants of the CALCM that would address limitations observed during Desert Storm, but it has not requested any funds.

The Desert Storm Air Campaign

When Iraq invaded Kuwait on August 2, 1990, U.S. military commanders began drafting plans for an air war against Iraqi targets in the event that Iraq attacked Saudi Arabia before sufficient U.S. ground forces were in theater. The commanders also began developing a four-phase plan to eject Iraqi forces from Kuwait. The first phase was for a strategic air campaign focused initially on decapitating Iraqi military and civilian command and control by a series of attacks against strategically vital targets, followed by attacks against fielded military forces. Five basic categories of targets—command and control, industrial production, infrastructure, population will, and fielded forces—were encompassed in the plan.

The most important targets were command, control, and communications targets, which were to be struck forcefully to incapacitate Saddam Hussein's ability to control his nation, disrupt the Iraqi forces, and induce the Iraqis to withdrawal from Kuwait. Attacks on key production and infrastructure targets would follow to further fracture the country and degrade Iraq's ability to replenish its forces. Attacks on targets such as television and radio stations and electrical power generation and distribution facilities, would degrade the will of the civilian population. Finally, in preparation for a coalition ground assault, Iraqi forces in the field would be struck.

Three other phases were to follow. The intent of the second phase was to gain air superiority, and the third phase was to reduce the capability of the Iraqi ground forces before the coalition ground attack. The fourth and final phase was the coalition ground attack into Kuwait. Figure 2.1 shows the Desert Storm area of operation and distances to target sites.

Figure 2.1: Desert Storm Area of Operation

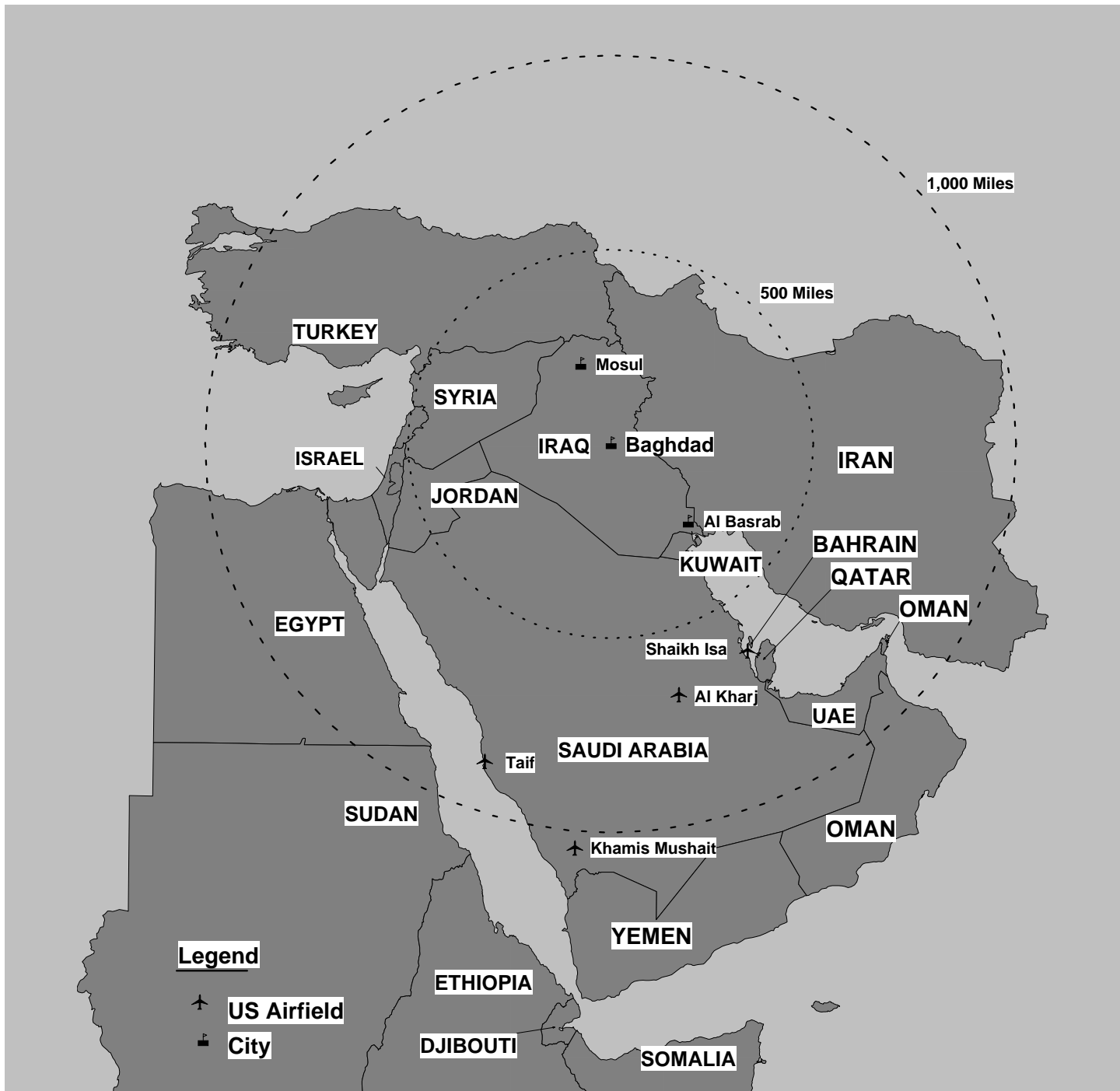

Source: Our analysis of Gulf War Air Power Survey data.

Even though the size and duration of the air plan changed before the start of the air campaign on January 17, 1991, its basic premise remained unchanged. Phase I attacks on Iraqi air defense facilities, the electrical power system, and command and control targets were carried out predominately by the F-117A, F-111F, F-15E, and A-6E aircraft, all of which carried precision munitions such as laser-guided bombs, and by Tomahawk cruise missiles and CALCMS. In total, coalition fixed-wing aircraft launched more than 40,000 individual attacks against targets in Iraq and occupied Kuwait during the campaign.

Cruise Missiles' Performance in Desert Storm

Tomahawks and CALCMS struck heavily defended targets deep in Iraq whose destruction was vital to the success of the Desert Storm air plan and that, if attacked by aircraft, could have led to unacceptable losses of aircraft and aircrews. Most cruise missiles were fired early in the campaign. Navy ships attempted to launch a total of 297 Tomahawk missiles. Of the 288 that were launched, 282 (95 percent) achieved cruise flight and proceeded toward their target.¹ Of the 39 CALCMS carried to launch points by B-52s, 35 (90 percent) were launched and proceeded toward their target.

According to data in studies conducted by the Center for Naval Analyses (CNA) and the Defense Intelligence Agency (DIA) and our analysis of Gulf War Air Power Survey data, both missiles achieved results approaching those of manned aircraft, such as the F-117A, during Desert Storm.

DOD and Navy officials said that multiple weapon strikes on many of the aim points and a lack of timely battle damage assessment during Desert Storm made it very difficult to determine the effectiveness of the Tomahawk and the CALCM. Target analysts were unable to obtain damage assessments for each aim point after each attack. Since many targets were attacked more than once by both aircraft and cruise missiles, it was an arduous task to determine which attack caused the observed damage in those cases. Additionally, since many aim points were also targeted by multiple missiles, it was difficult for the analysts to determine how many weapons caused the resulting damage.

¹Of the 297 attempted launches the 9 missiles that did not launch suffered various launch and system-related failures. Of the six missiles that launched but did not achieve cruise flight, five had problems deploying their wings, and the booster engine of one failed to separate from the missile.

DOD officials said that the missiles' mission objectives must be taken into account when measuring the missiles' success. Even if intended targets are not destroyed, a military objective can be met if the targets are rendered unusable or damaged as a result of being struck by some of several missiles targeted against it.

Tomahawk missiles struck targets in 8 of the 12 overall target categories.² The emphasis placed on the categories changed between the first 2 days and the remainder of the conflict. However, over the course of the campaign, the majority of the Tomahawks that were fired were launched against targets in four specific strategic target categories.

According to Navy officials, the 38 target complexes that Tomahawks attacked were all heavily defended and lent themselves to attack by an accurate, unmanned weapon such as the Tomahawk. Many of these targets were similar to those struck by manned aircraft. In many cases, the Tomahawk and manned aircraft not only struck the same categories of targets but also the same complexes. For example, Air Force aircraft launched 355 strikes—239 by the F-117A—against complexes that were also struck by the Tomahawk. Navy aircraft launched 185 strikes against complexes that were also struck by Tomahawk.

The Tomahawk's geographic reach equaled or exceeded that of manned aircraft. Many of the targets the Tomahawk and manned aircraft attacked were located in the same areas of Iraq. The Tomahawk's range allowed it to strike its targets flying from launch points in the Mediterranean and the Red Seas, and the Persian Gulf. The F-117As, flying from bases in southern Saudi Arabia (see fig. 2.1), were refueled on all missions. In addition, Tomahawk missiles were the only weapons that struck targets in the downtown Baghdad area during daylight for most of the campaign. Even though the Air Force's F-117As attacked Baghdad-area targets at night throughout the campaign, attacks by other aircraft were stopped after Iraqi ground defenses shot down two F-16s on the second day of the conflict.³ Thus, the Tomahawk's use had the added benefit of maintaining psychological pressure on the Iraqis in and around Baghdad.

Navy officials believe that some Tomahawks may have been shot down by Iraqi ground-based antiaircraft artillery. However, there appears to be no evidence that surface-to-air missiles contributed to Tomahawk kills. These officials also said that Tomahawk's flight profile made it difficult for

²Of the selected weapons, only the F-117A struck targets in all 12 categories.

³The F-117A was only employed at night, since it was visible to the naked eye during daylight.

surface-to-air missile systems to successfully identify and attack Tomahawks.

The limited number of routes used by Tomahawks to approach Iraqi targets and the tactics employed to ensure coordination with tactical aircraft missions may have contributed to missile losses. Because the usable routes into Iraq were so limited, multiple Tomahawks were launched along the same route. Thus, Iraqi gunners might have come to expect that, once a Tomahawk was sighted, others would soon follow along the same path. As a result, it would have been much easier to identify and engage the missiles that followed. According to a CNA study, the success rate for Tomahawks fired within the first 2 days of the air war was much higher than for those fired later, indicating that the Iraqi gunners might have become accustomed to seeing the missiles using certain routes and flying in stream raids.

Despite its limitations, Navy officials said that the Tomahawk's use provided a clear view of the missile's performance under arduous conditions. The flat, featureless terrain gave mission planners perhaps the most difficult task possible in creating the TERCOM and DSMAC scenes needed. The hot Middle East climate meant that the Tomahawk's engine was operating under the harshest possible conditions as well. Officials assert that the conditions under which the Tomahawk operated had to be considered when assessing the system's performance.

As with the Tomahawk, the CALCM contributed to the success of Operation Desert Storm but also demonstrated some limitations. On the first day of the conflict, seven B-52Gs carrying AGM-86C CALCMS took off from Barksdale Air Force Base, Louisiana, on a 35-hour, 14,000-mile round trip. All targets that the CALCMS attacked were in 2 of the 12 categories and consisted of 5 military communications sites and 3 electrical power stations. DIA's assessment of CALCM's damage to Iraqi targets concluded mission objectives were achieved against the majority of targets.

The cruise missiles were not the only systems that demonstrated limitations during Operation Desert Storm. Not all manned aircraft struck their intended targets. For example, as stated earlier, our analysis of Gulf War Air Power Survey data showed that the percent of the weapons carried aboard the F-117As that took off during the conflict and struck their intended targets was similar to the success rate achieved by the cruise missiles. The F-117As carried munitions on about 1,300 sorties, but

they released only about 79 percent of the weapons against their targets.⁴ Of those released, a high percentage struck their intended aim points. Poor visibility (overcast, fog, and smoke) limited the F-117A's ability to use its laser targeting and bomb guidance system. Almost 350 strikes were aborted after takeoff due to bad weather conditions alone. For example, more than half of the F-117A flights were unsuccessful on days two and three of the air campaign because of low clouds.⁵ In addition, bad weather halted operations for 2 consecutive nights during the later stage of the air campaign and during the final 2 days of the war. Another 76 strikes were aborted because the pilots had problems identifying the targets.

Other aircraft were also affected by various problems. For example, about 780, or 33 percent, of the 2,310 F-111F sorties were aborted before striking their targets because of mechanical and other problems and poor weather. Mechanical problems with various aircraft components, such as inertial navigation systems, air refueling systems, and digital computer complexes, caused nearly 45 percent of the aborts. Poor weather restricted the aircraft's ability to launch laser-guided bombs and caused nearly 25 percent of the aborts.

Tomahawk Performance Since Desert Storm

Since Desert Storm, U.S. forces used the Tomahawk to strike Iraq in two punitive raids. On January 17, 1993, U.S. forces struck the Zafraniyah Nuclear Fabrication Facility, located just outside Baghdad, in response to Iraq's refusal to cooperate with U.N. inspectors. Even though tactical aircraft were available, the National Command Authorities (i.e., the President and the Secretary of Defense) chose the Tomahawk for the strike because they wanted to avoid the potential loss of pilots or aircraft and unacceptable damage to nonmilitary targets. U.S. forces targeted 8 buildings and fired 46 Block II TLAM-C missiles, 42 of which (91 percent) were successfully launched and transitioned to cruise flight.

On June 26, 1993, Tomahawk missiles were used to strike the Iraqi Intelligence Service headquarters complex in the Baghdad area in retaliation for the plot to assassinate former President Bush. U.S. Central Command officials said that the Tomahawk was also chosen for this mission because it could strike the target without risking the loss of aircraft or aircrews. Additionally, an aircraft carrier was not present in theater at the time. U.S. forces targeted 6 buildings in the complex and

⁴A sortie is one aircraft taking off on one flight.

⁵Because it flies at a very low altitude, the Tomahawk is not as affected by bad weather in the target area as much as manned aircraft.

attempted to launch 25 Block II TLAM-C missiles, 23 of which (92 percent) were successfully launched and transitioned to cruise flight.

The Tomahawk's performance improved during the two strikes. The success rate was about 26 to 35 percent higher for the Zafraniyah raid, and 20 to 29 percent higher for the raid on Iraqi intelligence headquarters, than the success rate during Desert Storm.⁶

Tomahawk Improvements to Address Shortfalls and Expand Capabilities

Improvements already incorporated into the Block III Tomahawk cruise missile system, which is in production, address many limitations that were noted during Desert Storm. Table 2.1 illustrates the principal improvements incorporated into the Block III system.

⁶Navy officials said that 3 of the 23 missiles that successfully launched missed their aim points in the Iraqi intelligence headquarters raid because they were incorrectly programmed due to a mission planning software error. The missiles struck the aim points for which they were programmed. If these missiles were counted, the success rate for the raid would be 12 percent higher.

**Chapter 2
Cruise Missiles' Capabilities Have Been
Proven in Recent Conflicts**

Table 2.1: Block III Tomahawk Improvements That Address Desert Storm Limitations

Limitation	Improvement	Result
Tomahawk was not responsive to the tactical commander's needs, since route selections were limited, mission planning times were lengthy, and its arrival with tactical aircraft was difficult to coordinate accurately.	Global Positioning System guidance was added, mission planning hardware and software were upgraded and automated, Afloat Planning System was introduced, and Time of Arrival software was incorporated.	Route selections are expanded. Mission planning time is reduced by 90 percent. Theater commanders will have an in-theater mission planning capability. The Time of Arrival software allows strike times to be coordinated much more accurately.
Unitary warhead's penetrating ability was limited.	Warhead was redesigned, and programmable delay fuse was incorporated.	Lethality is increased because the missile can penetrate further into targets before the warhead detonates.
Some targets were at the extreme limit of the missiles' range.	Warhead and engine were redesigned.	The new, lighter warhead allows the missile to carry more fuel, extending the range. The redesigned engine provides more thrust and is more fuel efficient.
Stream raids alerted Iraqi defenses.	Global Positioning System guidance was added.	Since more routes to the targets will be available, defenders will not be alerted by the repetitive use of a few routes.

The Navy is also considering further evolutionary enhancements to the missile system through the Tomahawk Baseline Improvement Program, or Block IV. These enhancements would improve the system's capabilities over those of the Block III system, as shown in table 2.2.

Table 2.2: Tomahawk Block IV Improvements Over Block III

Capability	Block III	Block IV
Accuracy	CEP same as Block II	CEP 60 percent more accurate than Blocks II and III
Penetration	Greater than the Block II	Greater than the Block III
Mission planning time	Up to 90 percent shorter than Block II	Up to 50 percent shorter than Block III
DSMAC/TERCOM required for full accuracy	Yes	No
Data link—missile status	No	Yes
Data link—third party control	No	Yes
Antiship	No	Yes

^aThe Block III missile can fly missions using only the Global Positioning System for navigation, but the missile's CEP is greater than that of a Block II missile.

Because of the Block IV system's planned improvements, program officials estimated that attaining these requirements could reduce the number of missiles needed to defeat a group of targets by 40 percent. The Navy's fiscal year 1994 budget included funding to initiate the Block IV program. Production would begin at the conclusion of the Block III program, and the first Block IV missiles would be delivered about fiscal year 2000.

Although the Air Force is studying a proposal to upgrade the CALCM, it has not funded any improvements to the missile to address the limitations identified in Desert Storm due to competing funding priorities.

Agency Comments and Our Evaluation

DOD partially concurred with our assessment of the cruise missiles' performance during Desert Storm. However, DOD said that the data we presented for Tomahawk's performance was the result of a preliminary CNA study and did not represent the context in which the missiles were employed. Pointing out that about 80 percent of the weapons the F-117As released struck their targets, DOD said that the 63-percent success rate we stated for the F-117A was misleading because we considered more than only the weapons that were released against targets. It also said that refueling operations depend on the geography of the conflict and that refueling is often conducted to enhance flight safety.

CNA completed its study of the Tomahawk's Desert Storm performance after we submitted a draft of our classified report to DOD for comment. The study included an analysis of the number of missiles that struck their aim

points and the number of targets in which Tomahawk strikes achieved the intended military objectives. The final results were basically unchanged from the preliminary results we included in our draft report. We have incorporated the study's final results into this report.

We recognize that the Gulf War Air Power Survey data shows that about 80 percent of the weapons the F-117As released struck their target, but we believe that a success rate based only on the number of weapons released after the aircraft reached the target areas and successfully identified the targets is not comparable to the percentage of cruise missiles launched that struck their targets. We believe the number of weapons the F-117As carried from the airfields compares most directly with the number of cruise missiles that were launched from the ships and B-52s; therefore, we based our analysis on that number.

The success rate of the Tomahawk missiles that arrived in their target areas was much higher than the success rate of all missiles launched. Our analysis of data in CNA's final Tomahawk study shows that more than 75 percent of the TLAM-CS programmed for a terminal dive maneuver that arrived in their target area struck their intended aim point.

We agree with DOD's comment that aircraft are frequently refueled to enhance flight safety. However, as the Gulf War Air Power Survey points out, aircraft (including the F-117A) were frequently refueled during Desert Storm because the distance to the targets from their bases exceeded their unrefueled combat radius. Even though all future conflicts may not involve the ranges encountered during Desert Storm, the cruise missiles' range is an advantage.

DOD said that, even though our report implied that cruise missiles could be used interchangeably with manned aircraft, the Tomahawk's current capabilities restricted its use to fixed, nonhardened targets. DOD believed a range of weapons would be required to defeat many targets and that cruise missiles would be especially valuable early in an air campaign when used to create conditions more favorable to the large-scale employment of manned aircraft. DOD also said that the Air Force was considering improvements to the CALCM.

We agree that cruise missiles are best employed against fixed, nonhardened targets. We also agree, as discussed in chapter 4, that cruise missiles can be used to attack heavily defended targets in preparation for large-scale attacks by manned aircraft. However, we also believe, as

Chapter 2
Cruise Missiles' Capabilities Have Been
Proven in Recent Conflicts

Desert Storm showed, cruise missiles can be employed successfully against a wide range of the targets to be encountered in a conflict.

DOD also said that, even though our report stated that the Air Force had no plans to improve the CALCM, the Air Force is studying a proposal to improve the missile. We have modified our report to so indicate.

Cruise Missiles Broaden Options

The cruise missiles' performance in Desert Storm and the two subsequent Iraqi raids demonstrated that military commanders have a new option for highly accurate strike operations under a variety of conditions. During those conflicts, cruise missiles struck targets at night, in bad weather, or in the face of heavy air defenses without risking the loss of aircraft and the death or capture of U.S. aircrew members. In many cases, the cruise missile attacks achieved results similar to those of manned aircraft attacks.

Cruise missiles have other advantages over manned aircraft. For example, Tomahawk strikes do not require the additional resources—electronic warfare aircraft, fighter escort, and refueling aircraft—required for manned aircraft strikes. Additionally, as the raid on Iraqi intelligence headquarters demonstrated, cruise missile strikes can be launched without the presence of an aircraft carrier battle group. Employing cruise missiles can also avoid possible political constraints, such as obtaining host nation permission to use U.S. aircraft from forward deployed bases or fly through a third nation's airspace. Currently, 135 ships and submarines are equipped to launch Tomahawk missiles, which significantly expands the U.S. ability to conduct forward presence operations or respond to an adversary without the presence of an aircraft carrier battle group or conventional air forces. CALCM attacks can also be launched from U.S. bases, which allows the United States to attack an adversary without necessarily having forces nearby or risking the loss of U.S. aircrews. Reductions in mission planning times and other planned improvements could make the Tomahawk as responsive for strike missions as manned aircraft attacks.

Tactical aircraft systems have some advantages over cruise missiles and will therefore continue to play a key role in offensive strike operations. For example, aircraft-launched munitions can successfully attack a wider spectrum of targets than cruise missiles, such as those that are mobile, relocatable, or more hardened. Additionally, tactical aircraft systems are better suited for conducting large-scale or extended campaigns that encompass a large number of targets because of the greater amount of munitions needed and the munitions' relatively lower cost compared with that of cruise missiles.

Cruise Missiles Offer Additional Options for Attacking Targets

Both the Tomahawk and the CALCM broaden commanders' options by providing highly accurate strike weapons they can employ against a variety of targets at long ranges, under a variety of conditions, and without risking the loss of aircraft or aircrew. Cruise missiles also have other

advantages. For example, the Tomahawk uses fewer supporting resources to launch a strike, and planning times for the Tomahawk are equal to or better than aircraft in many cases. Additionally, the sea-launched Tomahawk and the U.S.-based CALCM are not subject to the same airspace and host nation basing restraints that can hamper employment of ground-based tactical aircraft. Table 3.1 summarizes and compares the advantages of cruise missiles and manned aircraft.

Table 3.1: Comparison of Tomahawk and Manned Aircraft

Factor	Cruise missiles	Manned aircraft
Risk to U.S. forces	No risk of loss of aircraft and aircrews	Potential loss of aircraft and aircrews
Target types		
Mobile	Cannot attack	Can attack
Fixed	Can attack	Can attack
Hardened	Not as effective	Effective
Support requirements	Launch vessel ^a	Aircraft carriers are supported by ships of battle group; Navy and Air Force strike aircraft require supporting aircraft (fighter, electronic warfare, command and control, and tankers)
Mission planning time	Block II has lengthy process; Block III and Block IV will have a relatively short process	Relatively short process
Access/basing rights	Launch from international waters	May require access to non-U.S. bases or airspace
Availability	135 launch vessels	Limited to aircraft carriers and air bases
Cost	High cost per missile	Very high acquisition cost for aircraft; relatively low cost for munitions

^aCruise missiles require extensive support to plan the mission. However, the launch vessel requires no external support after it receives the mission data.

Reduced Risk to U.S. Forces

Both Tomahawk and CALCM allow U.S. forces to strike an adversary with precision at long ranges without risking the loss of aircraft or aircrew, which is a significant factor in any decision to use military force. According to Air Force and Navy officials, the unwillingness to risk any losses was a factor in the National Command Authorities' decision to use

Tomahawks for the two 1993 strikes against Iraq. According to the officials, the public's reaction to the loss of any aircraft or aircrew during those raids would have diminished the raid's intended effect. Desert Storm illustrated that risk reduction was also important during an extended conflict.

Similar Effectiveness to That of Manned Aircraft Weapons

The destructive capabilities of the Tomahawk and the CALCM are generally similar to those of aircraft-delivered munitions of the same class. Thus, when used to attack targets that are susceptible to damage by their warheads, the Tomahawk's and CALCM's effectiveness is comparable to manned aircraft and the munitions they deliver. At our request, Air Force officials computed the expected probability of damage for the cruise missiles and guided bombs against a selection of common target elements. They considered factors such as construction of the target, weapon delivery accuracy, reliability, fuse, impact angle, and the targeted element's vulnerability to damage from the weapon. On the basis of a 70-percent probability of kill to the target, the Air Force's analysis showed that the numbers of cruise missiles required to destroy the target, when differences in warhead weights were considered, was comparable in most cases.¹

As its mission planning process is improved, the Tomahawk system is becoming as responsive, and in some case more responsive, to an operational commander as tactical aircraft.² Currently, if a preplanned Tomahawk mission for the target is aboard, a launch platform needs about 1 hour of preparation time to fire a missile. With the advent of the Block III system, missions will be able to be planned 90 percent faster than Block II missions, depending on the availability of imagery and the priority of the missions.

Strikes by manned aircraft also require extensive planning and preparation time. Navy officials said that the average strike by carrier-based aircraft can take 24 hours or more to plan and launch. During this period, the target imagery and surrounding defenses are analyzed, and the plan for all aircraft involved in the strike is prepared. The plan encompasses all the aircraft involved in the strike—the strike planes, electronic warfare support aircraft, fighter escort, and tankers. Meanwhile, other personnel

¹According to Navy officials, a 70-percent probability of kill results in a very high level of physical damage to the target. Depending on the objective of the strike, a lower probability of kill causes a lower level of physical damage but can achieve a useful military objective and require fewer weapons.

²The mission planning process is discussed in detail in appendix I.

prepare the aircraft for the strike. The weapons to be carried by the planes are taken from the ship's ammunition magazines, assembled, and moved to the flight deck. The ordnance and fuel are loaded aboard the aircraft, and the aircraft are aligned on the deck for launch. Once the mission plan is prepared and approved, the aircrews briefed, and the planes readied, the process of launching a 35-plane mission can take almost 1 hour.

Fewer Supporting Resources

Even though the Tomahawk requires extensive support in the mission planning process, the ships and submarines launching a Tomahawk strike require no additional resources after the strike has been ordered and the mission data provided. The crew executes the launch procedure, which can be done while the vessel is conducting other missions, such as antisubmarine or anti-air warfare. When launched, the Tomahawk is autonomous and requires no further support.

When both Air Force land-based and Navy carrier-based manned strike aircraft carry out their attacks, they are generally supported by several other types of aircraft. The supporting aircraft protect the strike aircraft from enemy defenses, provide command and control, and refuel the aircraft taking part in the attack. These groups of strike and support aircraft are commonly called "strike packages." Table 3.2 shows the aircraft that made up some typical Navy strike packages during Operation Desert Storm and the weapons they carried. Air Force strike packages were similarly constituted.

Table 3.2: Representative Navy Strike Packages in Desert Storm

Target	Aircraft		Ordnance
	Quantity	Type	
Aircraft maintenance and repair facility	4	F/A-18	4 HARM ^a and AA ^b missiles
	6	F/A-18	AA missiles
	6	A-6	6 MK 83 bombs
	2	EA-6B	3-4 ECM ^c pods
Communications sites	2	F/A-18	2 HARM and AA missiles
	11	F/A-18	3 MK 83 bombs and AA missiles
	2	A-6	2 TALD ^d and 1 Shrike missile
	2	EA-6B	3 ECM pods
Air defense sector operations center	2	F/A-18	2 Walleye missiles
	2	F/A-18	4 TALD and AA missiles
	9	F/A-18	3-4 MK 84 bombs and AA missiles
	2	EA-6B	4 ECM pods and 1 HARM
	8	F-14	AA missiles

Note: These strike packages do not include the airborne tankers, command and control, and protective fighter cover over the aircraft carrier.

^aHigh-Speed Anti-radiation Missile.

^bAir-to-air missiles.

^cElectronic countermeasures.

^dTactical Air-Launched Decoy.

Source: Navy data.

In those packages, the A-6 and F/A-18—depending on its configuration and weapon load—constituted the offensive strike aircraft. EA-6B electronic warfare support aircraft electronically jammed enemy defenses and attacked Iraqi radars with HARMs. F/A-18s, armed with HARMs and other weapons, also attacked Iraqi radar sites. To protect the other aircraft in the package from attacks by Iraqi fighter/ interceptors, a fighter escort was generally provided by F-14s or F/A-18s. Because of the distances between the aircraft carriers and Iraqi targets, extensive air refueling operations, both enroute to the target and during the return to home base, were required and were conducted by KA-6 or S-3 aircraft. Navy aircraft were also refueled by Air Force tanker aircraft.

Air Force aircraft also required extensive refueling support during Desert Storm. The distances from the airfields on the Saudi peninsula and from the aircraft carrier operating areas to the targets generally exceeded the operating range of the aircraft. For example, F-117As, with a combat

radius of 550-nautical miles, struck targets 905-nautical miles from their home base.

The January 1993 Tomahawk strike on the Zafraniyah nuclear facility illustrated the difference in resource requirements between the Tomahawk and manned aircraft. That raid was accomplished with 42 Tomahawk missiles launched from 4 ships. Navy officials said that a strike package of about 40 planes would probably have been used to conduct the same strike using carrier-based aircraft. A composite force of similar size composed of Navy carrier-based and Air Force land-based strike aircraft could also have been used.

Fewer Foreign Constraints

Because of foreign political constraints, the only forces the United States can employ unilaterally, in many cases, are carrier-based aircraft, U.S.-based bombers, and missiles aboard vessels operating in international waters. In a conflict, the United States may have to obtain a host nation's permission to launch strikes by U.S. aircraft from that nation's bases. For example, the U.S. government had to obtain specific authorization from the British government to utilize the F-111s based in England in the April 1986 strike against Libya.

Manned aircraft strikes may also be hampered if a third nation denies U.S. forces access to its airspace. In the 1986 Libyan raid, for example, the F-111s that took off from bases in England flew through the Straits of Gibraltar to reach Libya because the French government would not allow them to traverse French airspace. Cruise missiles launched from vessels operating in international waters off an adversary's coast or from U.S.-based bombers would not face such constraints.

Potentially More Available in a Crisis

As force levels decline and U.S. forces withdraw from overseas bases, cruise missiles may be the most immediately available weapons with which the National Command Authorities can respond in a crisis. The Navy projects that, by 1999, 137 surface ships and submarines will be Tomahawk equipped, and the number of deployable aircraft carriers will have decreased to 11. The Navy would then be unable to maintain a full-time aircraft carrier presence in the Mediterranean Sea, the Indian Ocean, and the western Pacific Ocean, as it has in the past.

Even though Tomahawk-capable ships and submarines operate as part of aircraft carrier battle groups, they also are capable of operating

independently or as part of surface action groups. The two vessels that launched the 1993 attack on the Iraqi intelligence headquarters operated independently. No U.S. aircraft carrier was within striking distance of Iraq at the time.

The ability to utilize overseas air bases and the time needed to deploy tactical aircraft could also slow the Air Force's response. Under those conditions, CALCM-armed B-52s, flying refueled missions from their U.S. air base, may be the most responsive Air Force weapon.

Tactical Aircraft Systems Retain Key Roles

Notwithstanding the capabilities of cruise missiles, tactical aircraft systems have significant advantages under many conditions and will therefore continue to retain a key role in offensive strike operations. For example, hardened targets generally can only be successfully attacked by aircraft-deployed munitions because of the Tomahawk's limited ability to penetrate these targets. In at least one instance in Operation Desert Storm, the Tomahawk was unable to penetrate the roof of a target it struck; a later attack by F-117As successfully penetrated the structure.

Only manned aircraft currently have the flexibility to successfully attack mobile or imprecisely located targets, such as tanks and other ground forces. The process of the pilot visually identifying the target before releasing the aircraft's weapons compensates for any target movement after the strike was planned or prestrike errors in location. Current cruise missile guidance systems, on the other hand, must be programmed before launch to guide the missiles to a geographic point that coincides with the targets' location. If such targets were programmed and then moved before the missile's arrival, the missile's path could not be corrected.

In addition, manned aircraft are better suited for striking the large number and variety of targets in a protracted conflict. For example, during the Desert Storm air campaign, over 1,000 strike aircraft flew more than 40,000 strikes against about 5,500 targets during the campaign.³ Large quantities of high-cost munitions, such as cruise missiles, are not available for use in such conflicts.

The comparative costs of the weapons also affect cruise missiles' suitability for extended campaigns. For example, the cost of attacking a target with a Tomahawk is higher than the cost of attacking it with manned aircraft because of the expected attrition rates for the aircraft. At

³These targets were fixed installations and not targets such as deployed troops and equipment.

our request, the Air Force analyzed the comparative costs of attacks by cruise missiles and F-15E, F-111, and F-117A manned aircraft against six common generic targets for a Southwest Asia 1999 scenario. The targets included a military command headquarters bunker, a petroleum refinery distillation unit, a control van for an SA-5 surface-to-air missile complex, an aircraft in a revetment, a thermal power plant generator hall, and a hardened aircraft shelter. The aircraft employed MK-84 unguided bombs, GBU-24 or GBU-27 laser-guided bombs, and the Joint Direct Attack Munition I.

The analysis determined the number of weapons and the associated cost to damage a target to a 0.8 probability of destruction throughout the duration of a campaign. The analysis' results were derived from weapon effectiveness reflected in the Joint Munitions Effectiveness Manuals and the weapon loads in the aircraft operating manuals. The costs per kill were derived from the individual costs of the sorties' weapon costs (e.g., \$2,000 for the MK-84 unguided bomb, \$60,000 for a GBU-24/27, \$392,000 for a CALCM,⁴ and \$1.8 million for the Tomahawk cruise missile); attrition; and direct support costs of threat suppression, tanker support, and electronic warfare obtained from Desert Storm historical data.⁵ Weather attrition factors were also included in the analysis, but the operating cost for the platform launching a Tomahawk, command and control aircraft for manned aircraft attacks, or the relative importance of manned versus unmanned systems were not considered. The analysis also did not consider or place any value on factors such as American aircrew members killed in action or captured as prisoners of war or collateral damage.

The analysis found that comparable numbers of laser-guided bombs, Tomahawks, and CALCM were needed to destroy some of the targets. However, because of the Tomahawk's and CALCM's higher unit costs, manned overflight systems would be more cost-effective against a wide variety of targets. For example, the cost to attack a petroleum refinery with F-117As employing a combination of GBU-27s and Joint Direct Attack Munition Is was about 96 percent less than the cost of attacking the refinery with the Tomahawk. Although the cost differential was less, Tomahawk and CALCM costs were also higher for attacking the thermal power plant because of the weapons' higher unit costs. The CALCM's cost was about 48 percent less than the Tomahawk's cost, and the F-117A's and

⁴This figure does not include the original acquisition cost of the Air Launched Cruise Missile that was converted into the CALCM.

⁵The Air Force's analysis used a cost of \$1.8 million for the Tomahawk, which is higher than the fiscal year 1984 unit cost of \$1.1 million per missile.

F-15's costs were about 88 and about 80 percent less, respectively, than the Tomahawk's.⁶

Agency Comments and Our Evaluation

DOD concurred with our assessment that manned aircraft would continue to play a key role in strike operations and provided several examples of what it considers to be the advantages of manned aircraft, such as the ability to attack mobile and hardened targets and the minimization of collateral damage. Although it concurred that cruise missiles provided commanders with additional options for strike operations, it said that the cost of using cruise missiles versus manned aircraft to reach an acceptable level of damage was very different. DOD also believed that our statement that cruise missiles do not require additional support resources was misleading because of the extensive requirements of the Tomahawk's mission planning process.

We agree that the munitions cost of an attack is less if manned aircraft are used considering the cost of the munitions and attrition rates of the manned aircraft. However, cost is only one measure of a weapon's suitability.

DOD's cost comparison of the F-117A strike on Iraqi Air Force headquarters and the 1993 Tomahawk strike on Iraqi intelligence headquarters does not portray the differing environments in which those two attacks were made. Although both weapons were suitable for attacking the targets, the F-117A strike on the Iraqi Air Force headquarters involved two aim points on one building and took place when the full array of coalition forces had already been deployed to Iraq and were conducting combat operations during the Desert Storm campaign. The 1993 Tomahawk strike was against a large target complex with multiple aim points located six separate buildings throughout the complex. A strike by manned aircraft would have required the time and resources of either deploying a carrier battle group to the area, since an aircraft carrier battle group was not in the area at the time, or obtaining host country authorization for the use of Air Force tactical assets based in the area. Employing the Tomahawk also responded to the National Command Authorities' desire to conduct the strike without risking the loss of aircraft and aircrew.

We also agree that the Tomahawk mission planning process requires considerable resources. A goal of the Block IV program is to reduce the

⁶The cost for the F-15E using the same weapons were higher than the costs for the F-117A throughout the analysis. Air Force officials attributed the cost difference to the lower attrition for the F-117A.

time and resources required for mission planning. However, we believe that the extensive support requirements of manned aircraft strikes must be taken into account when comparing the various systems. The 1993 Tomahawk strike on Iraqi intelligence headquarters is a clear illustration of this point. Extensive intelligence and target data would have been required to plan both a manned aircraft strike and a Tomahawk strike. However, after the Tomahawk mission data was prepared and transmitted to the ships, the launch vessels that were already operating in the area required no external support to launch the strike. On the other hand, all of the aircraft we discussed as making up a strike package would have been required to support a manned aircraft strike. We asked Navy strike planners how large a strike package would have been required if Navy manned aircraft had been used for the strike, and they said that as many as 40 to 45 aircraft could have been required.

We disagree with DOD's comment that one of the advantages of manned aircraft is the minimization of collateral damage. Even though the risk of collateral damage may be relatively low in attacks by aircraft employing precision munitions such as the F-117A, it can be a significant factor for other aircraft/weapon combinations. For example, the Gulf War Air Power Survey report notes that aircraft employing nonprecision munitions were not used to strike targets in urban areas because of the high risk of causing politically unacceptable collateral damage to civilian targets. Conversely, Navy officials told us that the Tomahawk was chosen to strike targets in several instances during Desert Storm because U.S. commanders believed the targets were too close to sensitive civilian targets to risk the collateral damage that could have resulted from manned aircraft strikes. Thus, even though collateral damage occurred during the 1993 Tomahawk strikes, we believe that an advantage of the Tomahawk is its low overall risk of collateral damage compared with manned aircraft.

Cruise Missiles' Proven Capabilities Should Affect Strike Aircraft Requirements and Force Structure Choices

Cruise missile capabilities should affect the design characteristics and quantity required for most future manned precision strike weapons systems as well as aircraft carrier force levels. Even though their capabilities overlap those of other strike weapon systems, cruise missiles have broadened the options available to commanders and have demonstrated that they are a viable strike capability in the absence of theater- or aircraft carrier-based strike aircraft. Therefore, most future strike aircraft may not require as long a range or as high a degree of stealth as originally planned. Also, fewer tanker, command and control, and electronic warfare aircraft may be required if cruise missiles are used to strike a larger portion of the targets.

According to DOD policies, an important objective of the defense acquisition system should be to minimize the overlap and duplication among weapon systems that perform the same or similar missions. However, we have previously reported that the military services justify such duplication on the basis of having complementary requirements to engage similar targets and, as a result, do not always consider alternative solutions.

The 135 ships and submarines currently equipped to launch the Tomahawk significantly expand the U.S. ability to conduct forward presence operations. If the warships were judged to be an acceptable alternative to an aircraft carrier battle group, considerable budgetary savings could result.

Cruise Missiles Can Affect Strike Aircraft Requirements

Cruise missiles' proven capabilities give U.S. decisionmakers viable alternatives to manned aircraft in several situations, such as the attack of heavily defended or long-range fixed targets. Those capabilities, used in collaboration with selected high-performance, manned strike aircraft, could affect the characteristics of most future manned aircraft. The resulting force of strike weapon systems would include both manned aircraft and cruise missiles and would have a range of capabilities.

Because its range allows it to attack fixed targets at distances that require manned strike aircraft to refuel, the Tomahawk could mitigate range requirements in most types of future manned strike aircraft. For example, the unrefueled range of the Navy's F/A-18E/F is expected to be 390 to 450 miles, and the unrefueled range of the F-117A is about 550 miles. As shown in a recent CNA study, a majority of the targets in many countries are within those ranges. The study analyzed strike range requirements for the

AF/X and found that, for the countries studied, a majority of the potential targets were relatively close to the countries' coast lines.¹

Longer range targets generally lend themselves to attack by weapons such as Tomahawk. Navy and Air Force officials noted that most long-range targets are fixed, high-value strategic targets, whereas mobile targets and ground forces are generally attacked at shorter ranges. Therefore, Tomahawks or aircraft such as the B-1, B-2, or B-52 could be used to attack most long-range targets, and, as a result, manned strike aircraft could be optimized for shorter range targets. According to Navy officials, not all targets are currently suitable for attack by cruise missiles, but most fixed targets will be susceptible to cruise missile attack with the advent of the Block IV Tomahawk.

Refueling remains an option when the range of manned strike aircraft must be extended to attack specific hardened targets. As pointed out in chapter 3, the F-117As were refueled for all their strikes during Desert Storm. Configuring most future Navy strike aircraft to conduct unrefueled strikes at ranges greater than those of current-generation strike aircraft may be unnecessary. Therefore, most future aircraft could be optimized to conduct attacks at shorter ranges, potentially resulting in procurement savings. Longer range targets could be attacked by, and would be vulnerable to, long-range bombers, Tomahawks, other cruise missiles, and refueled strike aircraft, when necessary.

Cruise missiles' ability to attack heavily defended targets without placing aircraft or aircrews at risk could also affect stealth requirements for most future aircraft and result in more affordable aircraft designs. Desert Storm demonstrated that the majority of U.S. aircraft can operate effectively without stealth technology. According to DoD officials, in the first days of the air campaign, cruise missiles acting with a limited number of F-117A and nonstealth defense suppression aircraft, such as the F-4G and EA-6B, effectively incapacitated the Iraqi air defense system and rendered it largely ineffective after day 3. This created a relatively benign environment in which nonstealth aircraft operated with near impunity for the remainder of the conflict. As a result, Air Force officials said that, once the air defense system was degraded, the F-117A was valued more in many cases for its precision bomb dropping capability than for its stealth characteristics. These officials also said that the degradation of enemy air defenses is likely to be a top priority in any future conflict, as it was during Desert Storm. However, as both Desert Storm and the 1993 strikes

¹The Navy had subsequently canceled the AF/X program.

demonstrated, Tomahawks can be used instead of manned aircraft when a high level of defenses remain or a defense suppression campaign may not be practicable.

Configuring most future strike aircraft with stealth capabilities may be unnecessary. A small force of stealth strike aircraft, such as the F-117A or its successors, could be maintained to attack well-defended targets along with cruise missiles such as the Tomahawk, and the majority of these aircraft could have a more conventional configuration, resulting in procurement savings.

Other existing and planned standoff weapons, such as the Joint Standoff Weapon, and the Standoff Land Attack Missile, will also permit strike aircraft to remain outside of the range of a target's defenses while conducting an attack, further reducing the need for stealth characteristics.

Services Do Not Always Consider Alternatives

DOD acquisition policies require analysis of mission needs, costs, and alternatives to ensure that cost-effective solutions are matched to valid requirements before substantial resources are committed to a particular program. According to those policies, an important objective of DOD's acquisition system should be to minimize the overlap and duplication among weapon systems that perform the same or similar missions, including when more than one service participates in similar missions areas. However, we previously reported that the services justify acquisitions of new systems on narrowly defined tasks or on a unique weapon system capability because they believe they have complementary requirements to engage similar targets.² As a result, alternative systems are not always considered. For example, in July 1993, we reported that the analysis of theater air interdiction in the Chairman of the Joint Chiefs of Staff's report on the roles, missions, and functions of the armed forces considered only fixed-wing aircraft and did not consider options for using land- or sea-based missiles and long-range artillery.³ Also, in April 1992, we reported that the Air Force and the Army gave little, if any, consideration to the contributions of other close support weapons when determining close air support requirements.⁴ In both reports, we said that actions should be taken to minimize the overlap among weapon capabilities.

²Weapons Acquisition: A Rare Opportunity for Lasting Change (GAO/NSIAD-93-15, Dec. 1992).

³Roles and Functions: Assessment of the Chairman of the Joint Chiefs of Staff Report (GAO/NSIAD-92-200, July 15, 1993).

⁴Major Acquisitions: DOD's Process Does Not Ensure Proper Weapons Mix for Close Support Mission (GAO/NSIAD-92-180, Apr. 17, 1992).

Both the Navy and the Air Force have tactical aircraft upgrade programs underway that will require major expenditures. These programs will result in retiring some aircraft types, modifying existing aircraft to enhance their strike capabilities, and developing new aircraft. The Navy is developing the F/A-18E/F, which it expects to be its primary short- to medium-range carrier-based attack aircraft. It estimates the total cost of the F/A-18E/F program to be about \$85 billion for 1,000 aircraft. The Navy is also modifying the F-14 to provide it with a strike capability and plans to retire all its A-6 medium strike bombers, its only carrier-based, long-range, all-weather strike aircraft. Additionally, the Air Force plans to incorporate a precision ground attack capability into the F-22.

Cruise Missile-Equipped Platforms Can Provide Forward Presence and Crisis Response

As the June 1993 raid on Iraq demonstrated, cruise missiles provide the United States with a viable strike capability in the absence of aircraft carrier-based strike aircraft. DOD's Bottom-Up Review stated that only 10 carriers were required for waging two nearly simultaneous major regional conflicts but that 11 were required to meet peacetime forward presence requirements in three worldwide regions. The review noted that the planned aircraft carrier force level of 11 active carriers and 1 training carrier would support regional forward presence 12 months per year in one region but would result in an average 4-month gap in carrier presence per year for the two remaining regions. The review also stated that a force of 10 carriers would increase the average gap in carrier presence in the two regions to 6 months. The review depicted a 4-month gap as an acceptable risk and a 6-month gap as unacceptable.

The 135 ships and submarines currently equipped to launch Tomahawk missiles significantly expand the U.S. ability to conduct forward presence operations, and the Tomahawk's capabilities may lessen the risk associated with the additional 2-month gap in presence. Those ships and submarines also expand the U.S. ability respond to an adversary in a crisis without the presence of an aircraft carrier battle group or conventional air forces. In addition, CALCM attacks can also be launched from U.S. bases, eliminating the need for any U.S. forces present in theater.

If the Tomahawk-capable warships were judged to be an acceptable alternative for conducting presence operations, the Navy could achieve considerable budgetary savings. As we previously reported, the average annualized cost of an aircraft carrier battle group was about \$1.5 billion.⁵

⁵Navy Carrier Battle Groups: The Structure and Affordability of the Future Force (GAO/NSIAD-93-74, Feb. 25, 1993).

Recommendations

We recommend that the Secretary of Defense assess the extent to which cruise missiles could affect the requirements for manned strike aircraft and aircraft carriers. This assessment should examine the (1) effect that existing cruise missiles and potential upgrades have on the design characteristics, such as the range, payload, and stealth characteristics, of planned future aircraft; (2) potential effect of the resulting alternative aircraft designs on future aircraft affordability; and (3) degree to which increased cruise missile inventories could affect the number of aircraft to be procured. We also recommend that the Secretary of Defense reassess the degree to which cruise missile-equipped platforms could fulfill peacetime presence requirements and the effect that increased reliance on those platforms would have on the Bottom-Up Review's justification for an additional aircraft carrier for presence missions.

Agency Comments and Our Evaluation

DOD partially concurred with our assessment of cruise missile's potential effect on the design characteristics of future aircraft, but it disagreed with our recommendations. It believes that cruise missiles and manned aircraft must be viewed as complementary systems and that cruise missiles are best suited to small, punitive operations and manned aircraft can better meet the overall requirements of supporting two major regional conflicts. We agree that cruise missiles and manned aircraft are complementary systems, but we continue to believe that cruise missiles should affect design characteristics of future aircraft. The range issue illustrates our point. Officials that prepared the F/A-18 E/F and the AF/X cost and operational effectiveness analyses said, in the campaign summaries supporting these analyses, that systems such as Tomahawk missiles and long-range bombers were used to attack many of the longer range targets, which tended to be more fixed than shorter range targets. Therefore, they said that both aircraft, although not excluded from attacking the longer range targets, were generally used to attack shorter range, more mobile targets. The officials also said that a shorter range—combined with other tradeoffs—was adequate for both aircraft, particularly the AF/X. We believe that such analysis should be applied to all future aircraft designs to ensure that cruise missile capabilities are fully exploited.

DOD believes that the range and stealth characteristics of manned aircraft must be viewed in the total context of the myriad competing priorities—such as range, payload, and survivability—in an aircraft's design and that these requirements in an aircraft's design are independent of cruise missile capabilities. DOD also said the campaign analysis supporting the F/A-18E/F cost and operational effectiveness analysis

summary addressed the employment of Tomahawk. It also said that it considered the Tomahawk's contributions, on a limited basis, in other strike aircraft tradeoffs.

We agree with DOD's comment that an aircraft's stealth requirement is driven by the missions it will fly and that all aircraft would benefit from the various signature reductions that are part of stealth. However, we continue to believe that if cruise missile capabilities are fully considered, tradeoffs may be possible. If, as DOD said, cruise missiles are especially useful in the early stages of an air campaign to create more favorable conditions for the large-scale employment of manned aircraft, manned aircraft can be employed in a more survivable environment. As a result, the design of most strike aircraft could include a less costly, though still adequate, stealth capability. Therefore, a less costly overall mix of aircraft could be employed. As Desert Storm demonstrated, heavily defended targets can be successfully attacked by cruise missiles and a limited number of highly capable and survivable aircraft, leaving other targets to be attacked by less survivable aircraft.

A recent CNA study reinforced this point. In an analysis of the Tomahawk's effect on modernizing naval aviation, CNA found that planned Tomahawk forces were suitable for attacking a modest number of heavily defended and deep targets early in a campaign and that capability reduced the need for naval aircraft to carry out those missions.

Although it agreed that aircraft carrier presence has been reduced as the Navy's force structure declined, DOD said that cruise missiles were only partial substitutes for the ability of an aircraft carrier and its associated battle group elements to provide forward presence. Cruise missiles cannot conduct the variety of missions the elements of an aircraft carrier battle group are capable of conducting, and cruise missiles do not provide the visibility—a key tenet of forward presence—that a carrier battle group provides. DOD believed that, although cruise missiles are an excellent addition to the U.S. conventional arsenal, the forces identified during the Bottom-Up Review were needed to win two nearly simultaneous major regional conflicts while providing forward presence.

We agree with DOD that cruise missiles do not provide the full range of capabilities inherent in an aircraft carrier battle group, either from the standpoint of providing peacetime presence or responding to a crisis. However, we believe that the full capability of an aircraft carrier battle group is not required in every situation to show U.S. resolve and

Chapter 4
Cruise Missiles' Proven Capabilities Should
Affect Strike Aircraft Requirements and
Force Structure Choices

commitment or forestall actions by other nations. The July 1993 strike against the Iraqi intelligence headquarters provided potential adversaries with a very tangible demonstration of U.S. capability that they cannot safely disregard. Additionally, as one Pacific Command official pointed out, potential adversaries cannot discount the possibility of the presence of Tomahawk-equipped submarines, even though the submarines are not visible. Furthermore, the July 1993 strike's effect was not tempered by U.S. losses, as were the strikes in Lebanon and Libya. Therefore, even though a system such as Tomahawk may not address all peacetime presence situations, we still believe that cruise missiles provide useful options for conducting peacetime presence missions and that our recommendation is valid.

Tomahawk Improvements Address Limitations

An upgraded Block III Tomahawk variant is in production. The resulting changes to the missile address many of the system limitations noted during Operation Desert Storm and expand the system's capabilities for future conflicts. A follow-on Block IV upgrade, which is under consideration, would further expand the missile's capabilities.

Tomahawk Block II Mission Planning Limitations

During Desert Storm, Tomahawk operations were hampered by the lengthy mission planning process and the stringent geographic information requirements of the Block II system. According to a Navy official, mission planning times took as long as 72 hours during the conflict. Also, it was difficult to find routes leading to targets that were usable by the Tomahawk's navigation system because of the relatively flat, featureless, desert terrain in the area.

Planning a Block II Tomahawk mission is an extensive process. All Block II Tomahawk missions are currently planned at two land-based facilities or Cruise Missile Support Activities (CMSA), located at Headquarters, U.S. Pacific and Atlantic Commands. During the mission planning process, planners must identify a route extending from a fixed starting point to the target. The route must be within the missiles' range, must not contain any obstacles to its flight such as steep mountains or concentrations of enemy air defenses, and must pass over terrain that would allow planners to prepare usable Terrain Contour Matching (TERCOM) maps and Digital Scene Mapping and Area Correlation (DSMAC) images. Planners must also identify specific aim points on the target whose destruction will achieve the desired military effect. Finally, planners must select a terminal maneuver—the manner in which the missile impacts the aim point—and the number of missiles needed to achieve the desired level of destruction.

The Block II missiles' need for TERCOM maps and DSMAC images significantly affects the planning process. The preparation of a TERCOM map requires high-quality geographic data of specific terrain features that meet stringent requirements for changes in elevation. The DSMAC process requires imagery of the intended scene that provides a specified range of contrast. Since the contrast of a ground scene can vary between night and day or with the changing seasons, the imagery must be specific to those conditions. The scene's precise geographic location must also be known. CMSAS obtain the TERCOM data from the Defense Mapping Agency, and a variety of intelligence activities provide the images CMSAS use to prepare the DSMAC scenes. The entire planning process for the Block II system, if

the TERCOM and DSMAC data is readily available, takes from 24 to 80 hours. If the required imagery is not readily available, Tomahawk mission planning can be delayed until the imagery is procured. Navy officials noted that this delay occurred during Desert Storm.

Planned missions are transferred to the Tomahawk-capable ship or submarine either through delivery of a data transport device (which is a large computer disk) or through radio communications channels. Once a ship or submarine is tasked to launch a Tomahawk, the process on board the launching vessel involves powering up the missile, aligning its inertial navigation equipment, transferring the mission into the missile's computer, and then launching the missile.

Navy and Air Force officials said that, after Desert Storm started, it was difficult to incorporate Tomahawk strikes into the evolving air campaign because of the Tomahawk's long planning times. That difficulty contributed to the missiles' heavy use early in the air war: about 75 percent of the missiles were fired during the first 3 days.

Tomahawk Block III Upgrade Program

The Tomahawk cruise missile Block III upgrade program is intended to increase the system's capability and its responsiveness to the needs of the tactical commander. The program encompasses improvements in all aspects of the weapon system—the missile, mission planning, and the fire control system. Block III development began before the Persian Gulf War, and the first missiles were delivered in April 1993. The improvements address many limitations in the system that were noted during Desert Storm.

Expanded Route Selections

One of the most significant improvements to the Block III missile is its added ability to navigate to targets using the Global Positioning System (GPS). GPS navigation frees the Tomahawk from having to fly over terrain that is suitable for and has been mapped for TERCOM navigation. Guiding from the signals of GPS satellites, a Block III missile can approach the target area from any direction and needs only to fly over one terminal DSMAC scene to achieve its full accuracy. The missile retains its ability to navigate to the target area with the TERCOM/DSMAC system. It can also navigate using only the GPS system; however the missile is three times less accurate in this mode. Figure I.1 illustrates the navigation modes of the Block III missile.

**Appendix I
Tomahawk Improvements Address
Limitations**

Figure I.1: Block III Navigation Modes

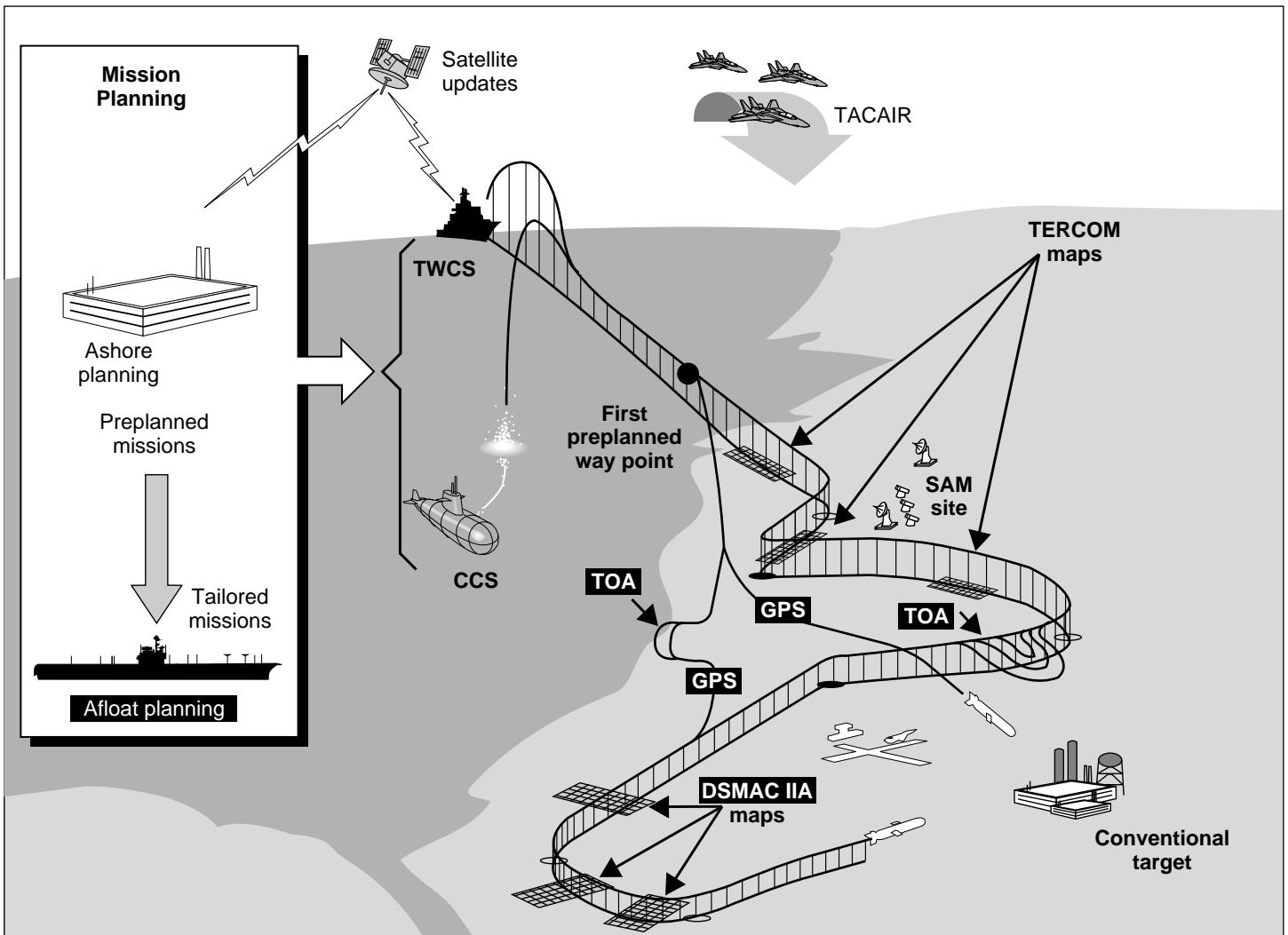

Note: CCS, Combat Control System; SAM, surface-to-air missile; TOA, time of arrival; TACAIR, tactical aircraft; TWCS, Tomahawk Weapon Control System.

Source: Navy.

The expanded selection of routes from which mission planners can choose should enhance the missiles' survivability. Navy officials believe that

mission planning limitations may have contributed to some Tomahawks being shot down during Desert Storm. The Block III missile's ability to approach the target area from any direction using GPS should reduce that vulnerability.

Reduced Mission Planning Time

Mission planning improvements will shorten the planning process. The improvements, which are in place and operational at CMSAS, include new software and workstations that automate many of the Tomahawk's mission planning tasks. As a result, according to Navy officials, missions using TERCOM maps and DSMAC scenes can be planned in 90 percent less time, with potentially fewer human errors. The flexibility to configure missions using only GPS to navigate to the target area and one terminal DSMAC scene, if the DSMAC imagery is available, will further reduce mission planning time by more than 60 percent. Additionally, Navy officials said that missions using only GPS to navigate could be planned in even shorter periods.

Navy officials said that the Block III upgrades were compatible with the Block II missile. Block III missiles can utilize Block II TERCOM/DSMAC missions and retain such benefits as the Block III's increased range and more lethal warhead. Both CMSAS will continue to plan Block II missions to support the Block II missiles that will remain in the inventory.

Enhanced Integration With Tactical Aircraft

The Time of Arrival control incorporated within the Block III missile's on-board computer adjusts the missile's speed and course so that it arrives at its target at a more precisely defined time. This control helps avoid airspace conflicts and weapon fratricide problems and can allow the aircraft to take advantage of disruptions of enemy defenses caused by cruise missile attacks.

Improved Warhead Lethality

During Desert Storm, the Tomahawk's inability to penetrate more heavily constructed targets limited its effectiveness. The Block II missile and its warhead can penetrate only about half the amount of concrete of the Block III missile, which incorporates a redesigned warhead that is lighter in weight than the Block II warhead—700 compared with 1,000 pounds—yet stronger.

The Block III's new warhead is equipped with a programmable delay fuse that increases the warhead's lethality. The new fuse can be programmed to

detonate at varying lengths of time after the warhead contacts the target, giving it additional time to penetrate into the target before exploding. This allows more of the warhead's explosive power to be spent damaging vital components inside the target. The Block II fuse has a single delay setting.

Longer Range

Many of the targets attacked during Desert Storm were near the Tomahawk's maximum range. Incorporating the new smaller, lighter warhead allows the missile body to carry more fuel, therefore increasing the range of the Block III TLAM-C. Additionally, Block III missiles are equipped with a more fuel-efficient engine that provides greater thrust. Since its warhead was not modified, the TLAM-D's range was not significantly changed.

More potential targets are within reach of the Block III TLAM-C because of its greater range, as shown in figure I.2. The additional range also allows the Tomahawk-equipped ships or submarines to remain further out from shore, thus increasing the distance from potential shore-based threats.

Figure I.2: World Areas Covered by the Block II and Block III TLAM-C Missiles' Range

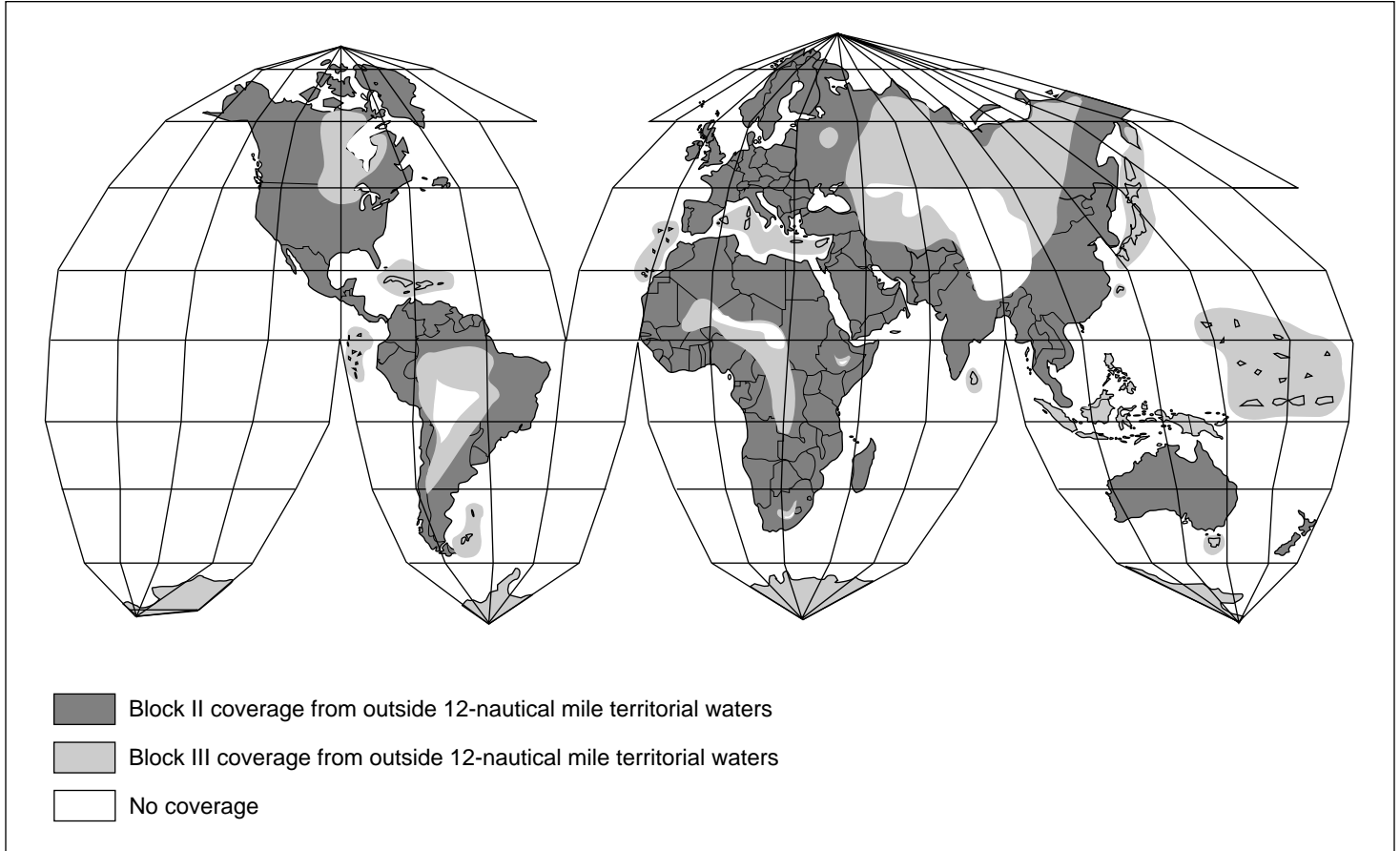

Source: Navy.

Mission Planning in Theater

The Block III program also introduces the Afloat Planning System (APS), which will provide Tomahawk mission planning capability to carrier battle groups and theater commands. According to Navy officials, this capability will make the Tomahawk more tactically responsive by reducing the need for CMSAS to plan all missions. Additionally, APS will allow the tactical commander to modify existing Tomahawk missions to meet the needs of the changing battlefield. APS suites will be deployed on aircraft carriers, and mobile vans containing APS suites will be deployable to theater command headquarters when needed. An APS suite consists of a single set of Tomahawk mission planning workstations that are identical in function to those located at CMSAS. The shipboard suites will be staffed by five personnel assigned to detachments located with CMSAS and four shipboard

personnel. The van-mounted suites will be staffed by nine personnel assigned to the detachments.

Tomahawk Baseline Improvement Program (Block IV)

The Navy is also considering further evolutionary enhancements to the missile system through the Tomahawk Baseline Improvement Program, or Block IV. According to program officials and documents, the upgrades under consideration would improve the system's capabilities over those of the Block III system. Program officials estimate that the Block IV system's planned improvements would reduce the number of missiles needed to defeat a target set by 40 percent.

Funding to initiate the Block IV missile system's development was included in the Navy's fiscal year 1994 budget. Under the program, production would begin at the conclusion of the Block III production program, and the first Block IV missiles would be delivered about fiscal year 2000. Navy officials estimate that research and development costs should total about \$600 million through fiscal year 1999. According to current plans, all missiles produced under the program would be remanufactured from earlier Block II and TASM Tomahawks beginning about 1999. The Tomahawk inventory would then proceed toward a force consisting of Block III and IV missiles.

Modern Seeker Technology

One of the improvements being considered for the missile is incorporating an imaging seeker for terminal guidance, which would make the Block IV Tomahawk's guidance system significantly better than that of previous versions of the missile.¹ The Tomahawk currently flies a pre-programmed route to a specific geographic coordinate that coincides with the desired aim point on the target. If any errors are made during the planning process that instruct the missile to fly to a different point, or if an erroneous location is used for the target, the missile will miss its aim point. An imaging seeker is capable of target recognition, which would enable the Block IV missile to compensate, to some degree, for such errors. The Block IV missile would be programmed to fly to its target area using GPS and inertial navigation. When it arrives in that area, its seeker would search for the target. When the missile recognizes the target, it would home in and strike it. Because the new seeker could compensate for minor errors in mission planning or target location, Block IV should have an accuracy 60 percent greater than Blocks II and III.

¹The Navy is considering an imaging infrared seeker.

Simplified Mission
Planning

Block IV mission planning would be simplified if the missile was equipped with an imaging seeker. The TERCOM/DSMAC data gathering and planning process would be eliminated, since the missile would navigate using GPS. The Block IV's imaging infrared seeker would be capable of using target images from any source normally used for aircraft mission planning purposes, thereby eliminating the need for special intelligence imagery support for the Tomahawk. If target imagery is available, land strike missions should require about one-half the time to plan as do Block III missions.

Greater Target Penetration

Currently, the Navy is considering equipping the Block IV with a warhead capable of penetrating about twice the reinforced concrete than the Block III missile's warhead. Navy officials said that analysis showed that Block IV's penetration would allow it to defeat a high percentage of potential targets.

Anti-Surface Ship Capable

Navy officials said that the Block IV missile, with its imaging seeker, would give the Navy a long-range, antiship missile with target recognition capability and would reduce the number of missile variants ships must carry.² The imaging capability would be particularly useful in the crowded littoral waters where the officials expect most future surface ship engagements to occur. Current antiship missiles, such as TASM and Harpoon, use radar-based seekers that cannot discriminate among several returns and attack only the intended target. As a result, these weapons are of limited use in crowded waterways where potential target ships may be intermingled with neutral vessels. Navy officials said that the Harpoon was not used during Desert Storm for this reason.

Navy officials said that Block IV's imaging infrared seeker technology would be capable of carrying images of various surface ship types in its on-board computer. Thus, the seeker would be able to scan a target area containing several ships and would only attack a ship it recognized as matching the image of its intended target.

Added Data Links

The Navy is considering adding two data links to the Block IV missile. The links would increase the missile's effectiveness because fewer missiles would be used to strike previously damaged or improperly planned aim points. One link would transmit an optical image from the Block IV missile

²With a dual-capable missile, the vessels would only need to load one type of missile, rather than two.

while it is in flight to a third-party aircraft. The other would be a satellite data link.

The first data link would allow a controller on board an aircraft to adjust the missile's aim point for tactical or other reasons, for example, if the missile was slightly off course or the predesignated aim point had already been damaged and the controller wanted to designate another aim point. The data link would also allow an airborne controller to direct the missile to another target for tactical reasons, such as if the original target had already been destroyed.³

Even though the satellite data link's exact nature has not been determined, program officials note that, at a minimum, it would allow the missile to transmit a health status signal while in flight. That signal would apprise the launch platform of the missile's condition until impact. If the missile developed mechanical trouble during the flight, began to navigate incorrectly, or stopped broadcasting altogether (possibly indicating that a fatal malfunction had occurred or that it had been shot down), a back-up missile could be launched. The signal would also provide strike planners an initial battle damage assessment, since it would indicate if the missile impacted in the target area.

Block IV officials said that the satellite data link could also enable Block IV to receive signals. Command authorities could therefore abort a missile from its mission if success was in doubt, lessening the chance for unintended collateral damage. The satellite data link would also allow commanders to divert the missile to an alternate target, if tactical reasons dictated. Figure I.3 illustrates how the data links could function.

³Block IV is expected to be able to carry two to three missions in its on-board computer.

Appendix I
Tomahawk Improvements Address
Limitations

Figure I.3: Block IV Concept of Operations

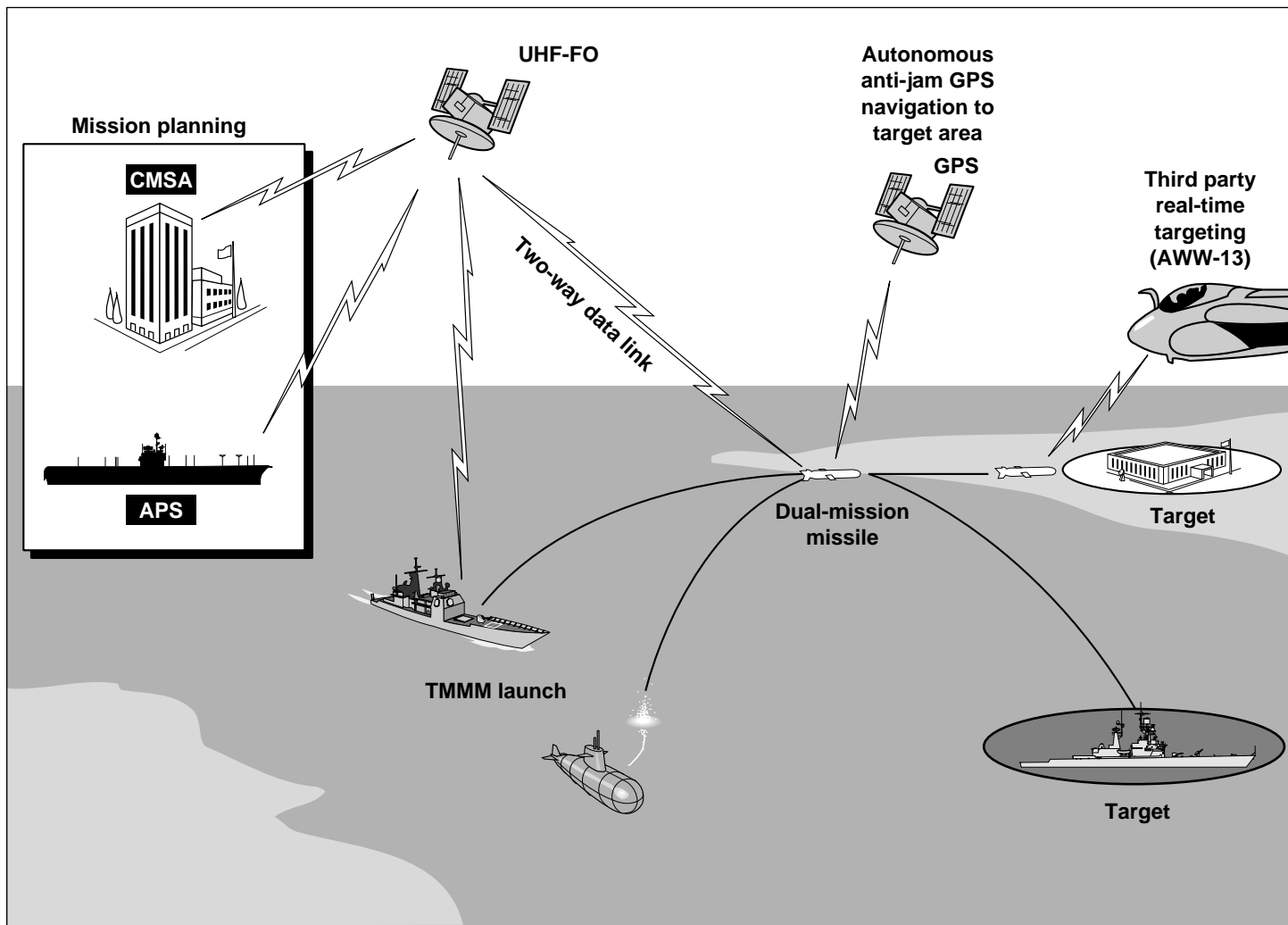

Note: TMM, Tomahawk Multi-Mission Missile; UHF-FO, ultrahigh frequency follow-on.

Source: Navy.

Major Contributors to This Report

**National Security and
International Affairs
Division, Washington,
D.C.**

Richard J. Price, Assistant Director
Tim F. Stone, Evaluator-in-Charge
Shawn M. Bates, Evaluator

**Norfolk Regional
Office**

Edward W. States, Regional Assignment Manager
Vincent Truett, Evaluator

Ordering Information

The first copy of each GAO report and testimony is free. Additional copies are \$2 each. Orders should be sent to the following address, accompanied by a check or money order made out to the Superintendent of Documents, when necessary. Orders for 100 or more copies to be mailed to a single address are discounted 25 percent.

Orders by mail:

**U.S. General Accounting Office
P.O. Box 6015
Gaithersburg, MD 20884-6015**

or visit:

**Room 1100
700 4th St. NW (corner of 4th and G Sts. NW)
U.S. General Accounting Office
Washington, DC**

**Orders may also be placed by calling (202) 512-6000
or by using fax number (301) 258-4066, or TDD (301) 413-0006.**

Each day, GAO issues a list of newly available reports and testimony. To receive facsimile copies of the daily list or any list from the past 30 days, please call (301) 258-4097 using a touchtone phone. A recorded menu will provide information on how to obtain these lists.

For information on how to access GAO reports on the INTERNET, send an e-mail message with "info" in the body to:

info@www.gao.gov

**United States
General Accounting Office
Washington, D.C. 20548-0001**

**Bulk Mail
Postage & Fees Paid
GAO
Permit No. G100**

**Official Business
Penalty for Private Use \$300**

Address Correction Requested

