

094863
REF-76-56
12-31-75

094863

REPORT TO THE CONGRESS



BY THE COMPTROLLER GENERAL
OF THE UNITED STATES

Improvements Still Needed In Coal Mine Dust-Sampling Program And Penalty Assessments And Collections

Departments of the Interior and
Health, Education, and Welfare

The Department of the Interior reported that 94 percent of the active underground coal mine sections were meeting the 2.0-milligram standard established by the Congress as the acceptable dust level. GAO found many weaknesses in the dust-sampling program affecting the accuracy and validity of results and making it virtually impossible to determine how many mine sections were in compliance.

Also, although the Mining Enforcement and Safety Administration has revised its procedures several times, penalty assessment, settlement, and collection continued to be untimely. Factors used to determine penalty amounts continued to be inconsistent and the Mining Enforcement and Safety Administration could not be sure that violations were assessed, settled, or collected. Improvements have been made; more are needed.

RED-76-56

~~706639~~
094863

DEC. 31, 1975



COMPTROLLER GENERAL OF THE UNITED STATES
WASHINGTON, D.C. 20548

B-170686

To the President of the Senate and the
Speaker of the House of Representatives

This is our report on improvements still needed in the
Department of Interior's coal mine dust-sampling program and
penalty assessments and collections.

We made our review pursuant to the Budget and Accounting Act,
1921 (31 U.S.C. 53), and the Accounting and Auditing Act of 1950
(31 U.S.C. 67).

We are sending copies of this report to the Director, Office
of Management and Budget; the Secretary of the Interior; and the
Secretary of Health, Education, and Welfare.

A handwritten signature in black ink, appearing to read "James A. Stacks".

Comptroller General
of the United States

C o n t e n t s

	<u>Page</u>
DIGEST	i
CHAPTER	
1 INTRODUCTION	1
The Federal Coal Mine Health and Safety Act of 1969	5
Operator sampling and Interior's enforcement of statutory provisions	6
Prior GAO reports	12
Scope of review	13
2 DUST SAMPLING PROGRAM RESULTS ARE UNRELIABLE	15
Federally established dust sampling procedures not followed by miners and mine operators	16
Dust sampling equipment and weighing of dust samples contributed to inaccurate measurements	24
Questionable methodology for compiling compliance statistics	29
Conclusions	30
Recommendations	31
Agency and manufacturers' comments and our evaluation	32
3 PENALTY ASSESSMENT AND COLLECTION PROCEDURES NEED TO BE IMPROVED	40
Timeliness and amounts of assessments and collections	40
Inconsistent application of assessment factors	42
Management controls over violations	44
Conclusions	45
Recommendations	46
Agency comments and our evaluation	46
APPENDIX	
I Letter dated March 12, 1974, to the Comptroller General from the Chairman, Senate Committee on Labor and Public Welfare	48
II Dust cyclone	50

APPENDIX

Page

III	Personal dust sampler and sampling head assembly	51
IV	Mine data card	52
V	Cassettes for personal samplers	53
VI	Principal officials responsible for the administration of activities discussed in this report	55

ABBREVIATIONS

BOM	Bureau of Mines
GAO	General Accounting Office
HEW	Department of Health, Education, and Welfare
MESA	Mining Enforcement and Safety Administration
MSA	Mine Safety Appliances Company
NBS	National Bureau of Standards
NIOSH	National Institute for Occupational Safety and Health
PTSC	Pittsburgh Technical Support Center

GLOSSARY

Air intake	Point where fresh air enters the mine section area within 200 feet of the working face of the section.
Cassette	The plastic enclosure into which the dust filter capsule is sealed which prevents contamination of the filter capsule.
Dust standards	Average concentration of respirable dust permitted in the mine atmosphere as required in the Federal Coal Mine Health and Safety Act of 1969.
Fibrosis	A condition marked by an increase of tough fiber-like tissue in the lung.
High-risk occupation	Mining occupation subject to the greatest dust concentrations.
Microns	A unit of length equal to one-thousandth of a millimeter.
Pneumoconiosis	A lung disease which coal mine dust may produce.
Respirable dust	Dust particles five microns or less in size not visible to the naked eye.
Section	All areas of a coal mine from the loading point, to and including the working face.
Sampler	Instrument used to determine the concentration of respirable dust in the coal mine atmosphere.

COMPTROLLER GENERAL'S
REPORT TO THE CONGRESS

IMPROVEMENTS STILL NEEDED IN
COAL MINE DUST-SAMPLING PROGRAM
AND PENALTY ASSESSMENTS AND
COLLECTIONS

Departments of the Interior and
Health, Education, and Welfare

D I G E S T

Department of the Interior officials, mine operators, miners, and union officials agree that significant improvements have been made in reducing the amounts of coal dust in mines since the Mining Enforcement and Safety Administration's respirable coal mine dust sampling program was begun in 1970. Respirable coal dust may cause a type of pneumococcosis commonly known as "black lung" disease.

Even so, GAO noted many weaknesses in the dust-sampling program which affected the accuracy and validity of the results and made it virtually impossible to determine how many mine sections were in compliance with statutorily established dust standards. (See p. 15.)

The uncertainty of the dust-sampling equipments' accuracy, improper or inadequate procedures followed by operators and miners taking the samples, and cassette weighing errors make, in GAO's view, current dust measurements unreliable, although the Mining Enforcement and Safety Administration has informed GAO that a cassette weight loss problem has been corrected. (See pp. 15 and 16.)

GAO recommends that the Secretaries of the Interior and Health, Education, and Welfare make further improvements in the dust-sampling equipment including the improvements recommended in a December 1975 report by the National Bureau of Standards such as flow rate regulators, alternate timing devices, more rugged components, and tamper-proof cassettes. (See p. 31.)

GAO further recommends that the Secretary of the Interior instruct the Mining Enforcement and Safety Administration and the Bureau of Mines and the Secretary of HEW instruct the National Institute for Occupational Safety and Health to conduct a joint study to determine quantitatively the accuracy and reliability of dust measurements when taken with the current equipment by coal miners in underground mines.

GAO suggests that the assistance of the equipment manufacturers and the National Bureau of Standards be solicited. (See p. 32.)

RED-76-56

Also, GAO recommends that the Secretary of the Interior instruct the Mining Enforcement and Safety Administration to take the following actions to help insure operators and miners follow proper sampling procedures:

- Develop procedures which would require operators to notify the Mining Enforcement and Safety Administration when samples will be taken so that it can consider using the information in scheduling mine visits.
- Discuss proper sampling procedures, in more detail, during training sessions for mine officials, and work with United Mine Workers of America and coal mine officials to help miners better understand the purpose of the dust-sampling program and the need to follow proper sampling procedures. (See p. 32.)

HEW and the equipment manufacturers generally agreed that the dust-sampling program has certain limitations. Mining Enforcement and Safety Administration officials stated, however, that the current dust-sampling program was primarily designed to reduce the respirable dust levels in coal mines and to show the direction and general magnitude of that reduction. (See p. 32.)

Certain improved interim procedures relating to penalty assessment and collection were implemented by the Mining Enforcement and Safety Administration and published in the Federal Register in April 1973.

Interim procedures appeared to be an improvement but were not effective because, as we had found in the past:

- Penalty assessments, settlements, and collections continued to be untimely. (See p. 40.)
- Factors used to determine penalty amounts were applied inconsistently. (See p. 40.)
- Penalties were significantly lower than amounts originally assessed and were a questionable deterrent to noncompliance. (See p. 40.)
- The Mining Enforcement and Safety Administration could not insure that all violations were assessed, settled, and/or collected. (See p. 40.)

On August 1, 1974, the Mining Enforcement and Safety Administration again revised penalty assessment, settlement, and collection procedures for coal mine health and safety violations.

Interior officials generally agreed with GAO findings which were based on the interim assessment procedures. They stated, however, that their current revised assessment procedures should correct the problems GAO noted. Based on a limited review of the new procedures, GAO believes, if they are properly implemented, they should result in more timely collections and should help insure that all violations are assessed, settled, and the fines are collected. However, GAO questions whether the new procedures will result in a proper level of consistency of assessments because of the subjectivity involved in determining the gravity of the violation. Also, GAO questions whether the amounts of the fines which will be less than before, will deter noncompliance of health and safety standards. (See p. 42.) The present penalties are smaller because they are based on amounts which have been previously collected.

The Secretary of the Interior should (a) instruct the Mining Enforcement and Safety Administration to clarify the newly defined assessment factors to help insure more uniform application of the factors and (b) require the Mining Enforcement and Safety Administration to evaluate the penalty assessment program to ascertain what penalties will best serve to deter violations and make appropriate revisions to the penalty schedule. (See p. 46.)

CHAPTER 1

INTRODUCTION

On March 12, 1974, the Chairman of the Senate Committee on Labor and Public Welfare asked us to review the dust-sampling program to determine the validity of its procedures and the accuracy of the Department of the Interior reports that 90 percent of the Nation's operating coal mine sections reduced the levels of respirable coal dust to amounts that were better than standards required by the statutes. The Chairman noted that because of the Nation's energy crisis, there is, and will continue to be, an ever-increasing need for greater quantities of coal. He expressed concern that in fulfilling this need, miners will again be subjected to levels of coal dust which exceed those of a healthy environment. This report is being issued to the Congress because of the dust sampling program's dangerous potential impact on coal workers and on the energy plan of the United States.

On May 22, 1974, the Chairman also requested the National Bureau of Standards (NBS) to evaluate the adequacy of

- personal samplers used by the Mining Enforcement and Safety Administration (MESA) to measure coal dust concentrations in mines (see app. III),
- Interior's procedures to analyze mine operators' dust samples, and
- any recent studies by Interior or private industry on coal dust sampling equipment.

The Committee requested that NBS' study be made in conjunction with our review. We are issuing our report concurrently with the NBS report entitled "An Evaluation of the Accuracy of the Coal Mine Dust Sampling Program Administered by the Department of the Interior."

We reviewed the Department of the Interior's implementation and enforcement of the provisions of the Federal Coal Mine Health and Safety Act of 1969 (30 U.S.C. 801) (1970), which requires that after December 30, 1972, the average concentration of respirable dust to which a miner is exposed cannot exceed 2.0 milligrams per cubic meter of air. The 1969 act defines respirable dust as particles five microns or less in size--particles which are not visible to the naked eye. Respirable coal dust may cause a type of pneumoconiosis commonly known as black lung disease. Since the enactment of the Federal Coal Mine Health and Safety Act of 1969 up to

November 1975 about 1,000 coal workers have been x-rayed and diagnosed as having coal workers pneumoconiosis.

The effects of pneumoconiosis are illustrated on the following page. These photographs were taken from the United Mine Workers of America publication "Black Lung."

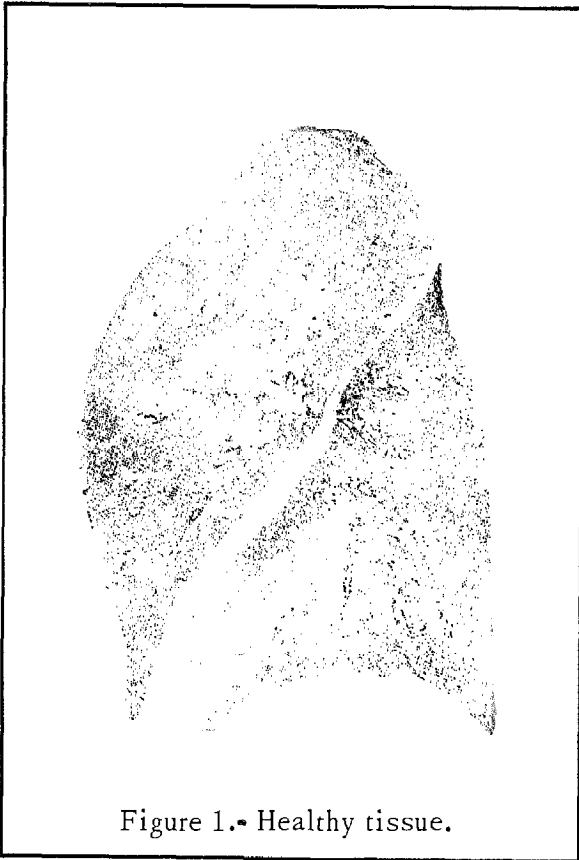

Figure 1.- Healthy tissue.

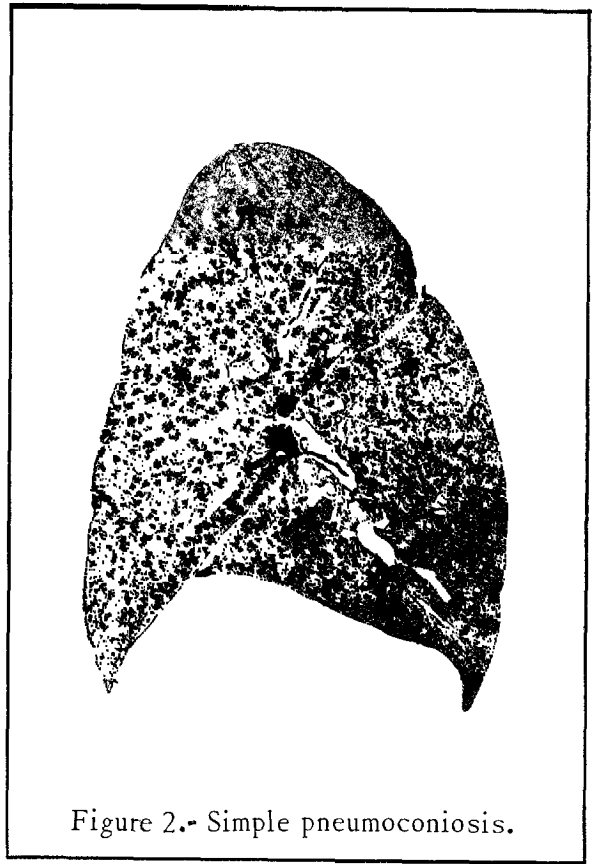

Figure 2.- Simple pneumoconiosis.

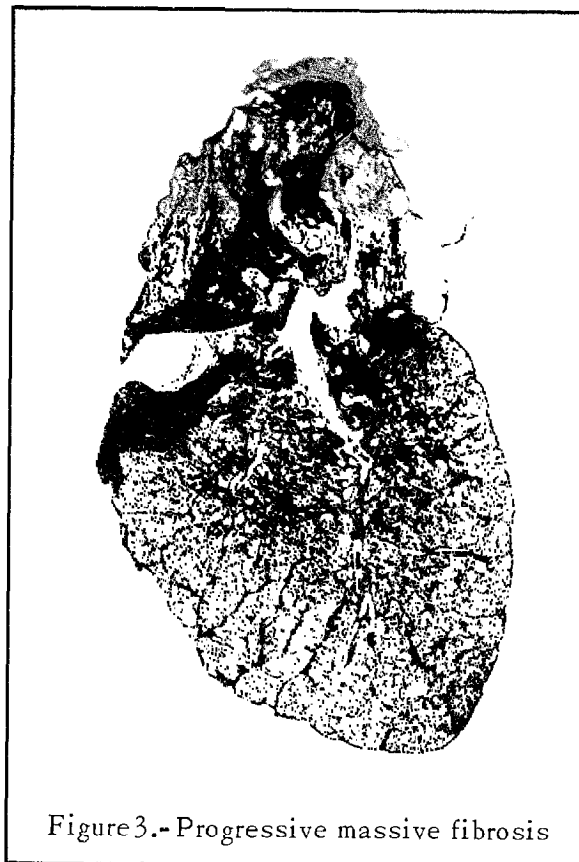

Figure 3.- Progressive massive fibrosis

Before enactment of the 1969 act, Interior's coal mine inspection program was conducted under the Federal Coal Mine Safety Act of 1952 (Act of Aug. 16, 1952, ch. 877, 66 Stat. 692). The 1969 act repealed the 1952 act and increased Interior's responsibilities among which were assessing and collecting civil penalties for violations of health and safety standards. Interior officials, coal mine operators, and miners we talked with during our review believed that, since the 1969 act, the amount of respirable dust in coal mines has been substantially reduced. Interior officials stated that before June 30, 1970, the average concentration of respirable dust in working sections was about 6.5 milligrams per cubic meter of air with sample peaks exceeding 25 milligrams. Currently, measurements made by MESA specialists, inspectors and the industry indicate an overall reduction to an average concentration of about 2.0 milligrams, with single sample values rarely exceeding 6.0 milligrams.

In accordance with the Chairman's request, we evaluated the adequacy and effectiveness of

- the coal mine operators' procedures under Interior's dust sampling program;
- Interior's analysis of dust samples and its compilation of statistics on the levels of compliance with the statutory respirable dust concentration standards;
- Interior's inspection program to insure compliance with specified dust standards; and
- Interior's assessment, settlement, and collection of fines for violations of statutory dust standards.

In accordance with the request, we did not review the implementation and enforcement of safety standards or other health requirements.

THE FEDERAL COAL MINE HEALTH
AND SAFETY ACT OF 1969

The purposes of the 1969 act are to (1) establish interim mandatory health and safety standards, (2) direct Interior and the Department of Health, Education, and Welfare (HEW) to promulgate improved mandatory health and safety standards to protect the health and safety of the Nation's coal miners, (3) require each operator and miner to comply with such standards, (4) cooperate with and provide assistance to the States in developing and enforcing effective State coal mine health and safety programs, and (5) improve and expand, in cooperation with the States and the coal mining industry,

research and development and training programs to prevent coal mine accidents and occupationally caused diseases.

The 1969 act requires operators to

- take accurate samples of the amount of respirable dust to which miners are exposed in active working areas of mines,
- take samples in the manner and at intervals prescribed by Interior and HEW,
- submit samples to Interior for analysis and determination of compliance with provisions of the 1969 act, and
- maintain an average concentration of respirable dust at or below 2.0 milligrams per cubic meter of air.

Operators who were unable to comply with the 2.0-milligram standard could obtain, from the Interim Compliance Panel, a five-member governmental body, noncompliance permits for up to 1 year during which time the dust levels should not exceed 3.0 milligrams per cubic meter of air. Permits allowing operators to exceed the 2.0-milligram level cannot be issued after December 30, 1975.

To help insure compliance with respirable dust provisions of the 1969 act, Interior is to inspect each underground coal mine at least four times a year. If mine operators are not taking the proper number of dust samples, are not following required sampling procedures, or if samples show dust concentrations in excess of the 2.0-milligram standard, Interior is to issue a notice of violation to the mine operator, establish a reasonable time for the operator to correct the violation, and assess a civil penalty.

OPERATOR SAMPLING AND INTERIOR'S ENFORCEMENT OF STATUTORY PROVISIONS

MESA, an agency under the Department of the Interior and established on May 7, 1973, is directly responsible for implementing and enforcing the 1969 act, which includes

- establishing the types and number of dust samples that mine operators must submit to MESA and the frequency for submitting them (referred to as sampling requirements),
- establishing dust sampling procedures,

- monitoring mine operator sampling,
- inspecting mines,
- issuing violation notices, and
- assessing and collecting fines.

MESA assumed these responsibilities from the Bureau of Mines (BOM) on July 16, 1973.

To implement the major provisions of the 1969 act, including those relating to MESA's monitoring of the respirable coal mine dust levels, the Congress appropriated the following funds to Interior for fiscal years 1974 and 1975.

<u>Purpose</u>	<u>1974</u>	<u>1975</u>
	(thousands)	
Inspections	\$35,663	\$40,863
Education and training	19,980	5,884
Technical support	7,588	9,144
Program administration	<u>1,389</u>	<u>1,516</u>
Total	<u>\$64,620</u>	<u>\$57,407</u>

Sampling requirements

Since June 30, 1970, mine operators have been required to operate dust-sampling programs to help Interior determine the levels of respirable dust in coal mines. Each operator must initially collect and submit 10 samples--one a day--from each coal-producing section of a mine. If MESA's analysis of the dust samples show that the mine section is within the dust concentration standards, the operator is then required to submit only five samples a month. If the operator continues to comply with the standard, MESA may then require that only five samples be taken every other month. The initial, monthly, and bimonthly sampling is referred to as the original, standard, and alternate sampling cycles, respectively. These samples are to be taken at locations of the greatest concentration of dust. Such locations are generally referred to as places of high-risk occupation.

With the high-risk occupation samples submitted, the mine operator must also submit one additional sample taken at a point where fresh air enters the mine section. The operator is also required to take one sample for each miner every 120 or 180 days depending on where he works in the

mine, or every 90 days for each miner who, because of evidence that he has pneumoconiosis, has been transferred to a less dusty area of the mine.

Dust samples may be taken with any personal sampler approved by Interior and HEW or with the Mining Research Establishment area sampler. (See p. 9.) As of the date of our review, four personal samplers were approved--two by Bendix Corporation and one each by Mine Safety Appliances Company (MSA) and Willson, Inc. However, almost all samples were being taken with the Bendix or MSA samplers because the Willson sampler was only recently developed. Dust samples are sent to MESA's Pittsburgh, Pennsylvania, Technical Support Center (PTSC) where they are weighed and analyzed. The samples are sent in a cassette which consists of a plastic enclosure into which the dust filter capsule is sealed. Sample weight data is then transmitted to BOM's data processing center in Denver, Colorado, where dust concentrations are computed to determine whether the mine sections are within the dust concentration standards.

MESA mine inspection program

MESA has 9 districts with 15 subdistricts. The BOM processing center notifies the subdistricts of the dust sample results. The subdistricts then notify the mine operators and, if warranted by the sample results, issue violation notices. The number of mines each district was responsible for on February 28, 1975, is shown on page 10.

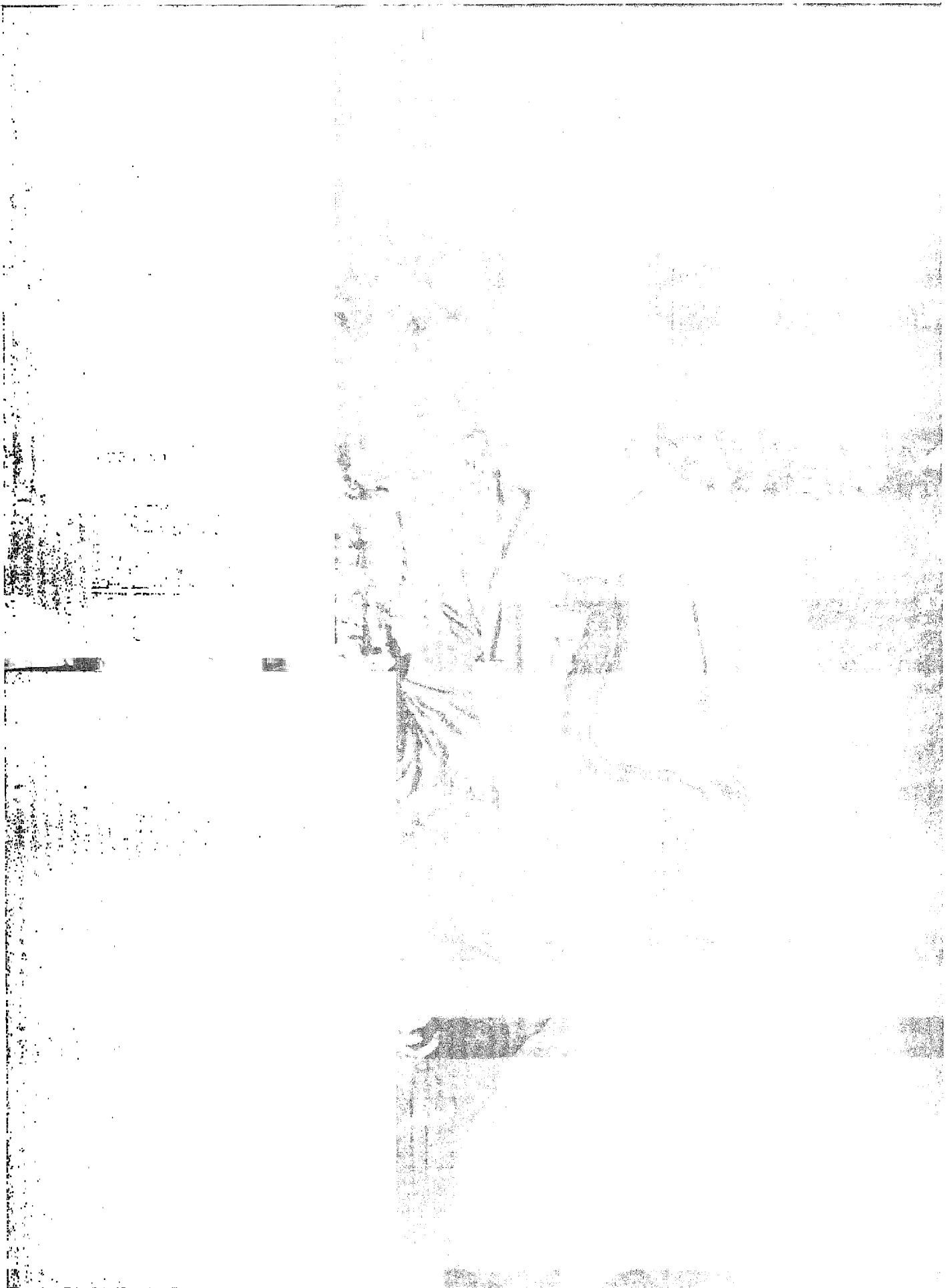

<u>District</u>	<u>Number of sub- districts</u>	<u>Number of mines</u>	
		<u>Underground (Note a)</u>	<u>Surface (Note b)</u>
Wilkes Barre, Pennsylvania	0	58	186
Pittsburgh, Pennsylvania	2	140	458
Morgantown, West Virginia	0	74	163
Mount Hope, West Virginia	3	456	288
Norton, Virginia	2	253	238
Pikeville, Kentucky	0	390	322
Barbourville, Kentucky	3	303	541
Vincennes, Indiana	2	58	294
Denver, Colorado	<u>3</u>	<u>47</u>	<u>108</u>
Total	<u>15</u>	<u>1,779</u>	<u>2,598</u>

a/ Includes active producing and nonproducing coal mines and mines under construction.

b/ Includes only active mines producing coal.

MESA's health inspection procedures require its inspectors to take dust samples to determine whether concentrations exceed the standards and whether the operator had properly implemented a sampling program. According to a MESA official, MESA began the necessary action to implement new health inspection procedures around September 1975 with increased emphasis on requiring mine operators to institute measures to control dust. Under this program, MESA will require (1) operators to institute dust control plans which will be tested and approved by MESA, (2) its inspectors to evaluate operators' dust control plans during their inspections, and (3) its health specialists to periodically review and test the adequacy of operators' plans by taking dust samples at 6-month intervals in each single section mine, and at least one of every five working sections in multisection mines where equipment, conditions, and dust control methods are similar.

Also under this program, MESA inspectors will request that samples be taken by health specialists only when they feel the operators' dust control procedures are inadequate. MESA field offices will be required to continue to cite mine operators for violations when they fail to meet concentration standards, or fail to properly take samples.

Penalty assessment and collection

MESA's Office of Assessment assesses civil penalties on operators who violate the dust requirements of the law. Since the 1969 act became effective, Interior has followed three

sets of procedures to assess and collect penalties. On August 1, 1974, MESA implemented its current procedures.

We evaluated the procedures that were in effect from April 24, 1973, through July 31, 1974 (interim procedures). MESA was recommending penalties under the interim procedures in accordance with an assessment formula which included

- the operator's history of previous violations,
- the operator's size,
- the operator's degree of negligence,
- the operator's ability to continue in business,
- the violation's gravity, and
- the operator's demonstrated good faith in attempting to correct the violation.

Under MESA's interim procedures the assessment offices recommended penalties including a civil penalty with proposed findings of fact to Interior's Office of the Solicitor. The Solicitor's Office notified the operator of the recommended penalty while simultaneously filing a petition to assess the penalty with the Office of Hearings and Appeals (Hearings Office).

Unless the operator paid the penalty, he had to respond to the Hearings Office within 30 days at which time he was scheduled for a hearing and so notified. The Solicitor's Office was authorized to settle the case before the scheduled hearing. If the operator did not respond or if he failed to appear at the hearing, the Hearings Office ordered him to show cause why he should not be held in default. Upon an unsatisfactory answer to the order, a Hearings Office administrative law judge could conduct a default hearing.

When the administrative law judge found that an operator had violated the law, he determined the amount of penalty to be paid, and incorporated findings of fact and conclusions of law in his decision. He also issued an order requiring the penalty be paid but was not required to use the assessment formula in determining the amount of the penalty. The operator could appeal the judge's order to the Board of Mine Operations Appeals.

The August 1, 1974, procedures provided for a revised penalty schedule and a new formula for applying the six statutory factors. In addition, the Office of Assessment,

notified the operator of the assessment and afforded him an opportunity to discuss the findings and/or to pay the penalty.

If the mine operator did not pay the penalty by a designated time or did not request a hearing with the Hearings Office, the order of assessment was enforced pursuant to Section 109 (a) (4) of the 1969 Act by filing a petition for enforcement in the appropriate district court of the United States.

PRIOR GAO REPORTS

In a May 13, 1971, report (B-170686) to the Subcommittee on Labor, Senate Committee on Labor and Public Welfare, we pointed out that:

- Interior was not making the required number of health inspections.
- Operators were not submitting the required number of dust samples.
- Operators in many cases were not submitting valid dust samples.

In a followup examination and report (B-170686, July 5, 1973), we noted that:

- Interior had made progress in carrying out the prescribed number of health inspections, but further efforts were needed to achieve full compliance with the required frequency.
- Most operators of active coal-producing mines were submitting samples, but some were still not submitting the required number.

Penalty assessment and collection

In a July 1972 report (B-170686, July 5, 1972) to the Conservation and Natural Resources Subcommittee of the House Committee on Government Operations, we reported that:

- Written guidelines had not been developed to aid assessors in considering the six statutory factors in making assessments.
- Consideration given to the factors by the assessors was not documented, and no such documentation was required by MESA.

- There were delays in (1) making assessments, (2) referring cases for hearings, (3) conducting hearings on cases disputed by mine operators, and (4) collecting penalties.

Based on a followup review conducted primarily at Interior's headquarters we reported on October 31, 1973, to the same subcommittee that:

- Interior improved its penalty assessment procedures by establishing guidelines enabling assessors to consider more systematically and objectively the six statutory factors and also to require assessors to document such information.
- There were long delays in assessing penalties and conducting hearings on cases.
- Interior did not have accurate data on penalties assessed and unpaid, and there was no management control system for identifying required collection actions.

SCOPE OF REVIEW

Our work on this request was done principally at the MESA district office in Mount Hope, West Virginia, which had 344 of the 1,400 underground coal mines producing coal on March 31, 1974, in the United States, and the assessment offices in Mount Hope and Charleston, West Virginia. We also did work at the PTSC in Pittsburgh, Pennsylvania; the subdistrict office in Madisonville, Kentucky; the BOM data processing center in Denver, Colorado; MESA's Division of Health and Office of Assessment in Washington, D.C.; Interior's Office of the Solicitor and Office of Hearings and Appeals in Arlington, Virginia; and met with representatives of the National Institute for Occupational Safety and Health (NIOSH), HEW.

In doing this work, we:

- Reviewed the legislative history of the act and the procedures for implementing the legislation.
- Examined pertinent documents, reports, records, and files at the various offices.
- Interviewed Interior officials, coal mine operators, coal miners, and coal mine workers' union officials.
- Accompanied coal mine inspectors to 14 underground mines to observe sampling procedures.

--Randomly selected 125 of the 344 underground coal mines producing coal in the Mount Hope District in March 1974 to analyze the operator sampling program and the MESA inspection program from January 1, 1973, through March 31, 1974.

--Selected 55 of the 125 mines for a detailed analysis of the assessment and settlement of penalties for dust sampling and concentration violations cited from January 1, 1973, through March 31, 1974.

--Mailed questionnaires to 167 coal mine operators and distributed questionnaires to 67 miners in the Mount Hope District to obtain data on the sampling program and sampling procedures.

In reviewing the legislative history of the act, we noted that there were many views both for and against the 2.0-milligram standard. Neither we nor NBS attempted to evaluate the established dust level standard.

CHAPTER 2

DUST-SAMPLING PROGRAM RESULTS ARE UNRELIABLE

The Secretary of the Interior, in his 1973 Annual Report on Federal Coal Mine Health and Safety, reported that about 94 percent of the underground coal mine sections were in compliance with the 2.0-milligram respirable dust concentration standard. During our review, Interior officials, mine operators, miners, and union officials generally agreed that significant improvements have been made in reducing the amounts of respirable coal dust in mines since MESA's respirable coal mine dust-sampling program was initiated in 1970. However, we noted many weaknesses in the dust-sampling program which affected the accuracy and validity of the results and which, in our view, made it under current procedures virtually impossible to determine how many mine sections are in compliance with statutorily established dust standards.

Factors of the program which contributed to inconclusive dust concentration measurements included

- sampling practices used by operators and miners,
- dust-sampling equipment,
- weight loss of cassettes, and
- weighing of the cassettes by MESA and the cassette manufacturers.

NBS estimates that the current minimum overall error in individual dust measurements is ± 32 percent when taken by trained scientists using meticulous care. MESA uses a sampling plan under which compliance is determined by averaging the results of the 10 most recent samples; therefore, some of the individual dust measurement error is statistically eliminated. Under MESA's sampling plan, NBS estimates that the overall uncertainty calculated for the average sample, the basis for determining compliance, is a minimum of ± 20 percent. However, neither of these estimates include the effect of:

- the physical impact and occasional inversions of the sampler that come from being worn by a miner during his normal work activities;
- less frequent adjustments and maintenance that can be afforded by the mine operator representative as compared to the scientists upon whose in-mine experiments these estimates are based;

- deviations from prescribed procedures that may go unnoticed and, therefore, produce an inaccurate sample;
- inadvertent or negligent alteration of the samples; and
- the cassette weight loss problem which has apparently been corrected in the last year.

NBS officials noted that it is extremely difficult to estimate the additional error resulting from user neglect and/or inexperience, and other improper practices, such as those which we noted during our review. However, they added that the additional error would be significant and that such factors could nearly double the estimated error rate.

FEDERALLY ESTABLISHED DUST-SAMPLING
PROCEDURES NOT FOLLOWED BY
MINERS AND MINE OPERATORS

Miners and mine operators have not always followed required sampling procedures. Therefore, dust samples taken by operators did not always represent actual dust levels in coal mines.

The 1969 act requires (1) mine operators to take accurate samples of the amount of respirable dust in the mine atmosphere, (2) the Department of the Interior to establish adequate sampling procedures, and (3) insurance that the procedures are properly followed. From 1965 to 1969, MESA's PTSC studied dust-sampling activities and the procedures for measuring coal dust concentrations. As a result, the Secretaries of the Interior and HEW established procedures which required that:

- Equipment for dust sampling be operated from the time the miner enters the mine until he leaves (portal to portal).
- Dust pump air-flow rates be maintained at 2.0 liters of air per minute.
- Equipment be on the miner or within 3 feet of his normal work position.
- Dust samples and data on the geographical location of the mine be sent to the PTSC. (See app. IV.)
- Elements of the sampler should be in good operating condition and properly connected. The elements include the sampling head assembly (cyclone, filter,

filter holder and tubing) and the pump unit. (See apps. II and III.)

--The cyclone which collects and separates respirable dust particles must be cleaned frequently. (See app. II.)

--The air-flow rate must be adjusted during the first hour of operation and at least one additional time during the production shift to maintain a flow of 2.0 liters per minute.

--The sampling head should always be kept in an upright position.

During our review, we accompanied MESA inspectors to 14 mines and observed 22 miners taking dust samples; some of the miners' practices did not comply with required sampling procedures. The following schedule lists the improper practices noted during our visits.

<u>Practices</u>	<u>Number of mines</u>	<u>Times observed</u>
Sampling head assembly and pump unit were from different samplers	2	4
Sampler was not continuously operated from the time the miner entered the mine until he left it (portal to portal)	8	10
Air-flow rate was not checked and/or was not maintained at 2.0 liters per minute	7	12
Sampler stopped running because of mechanical failure	2	3
Mine data card was completed, including the time the sampler was operated and the amount of coal produced, before the sample was taken	4	5
Individual being sampled was not within 3 feet of his sampler	2	3
Cyclone was dirty	1	1
Sampling head tilted	4	6
Sampler was turned on before entering mine portal	1	1

In summary, we observed improper sampling procedures at every one of the 14 mines we visited. As we previously discussed, NBS officials said that it would be extremely difficult to estimate the additional errors in the dust level measurements resulting from practices such as those mentioned above; however, they added that such practices could nearly double the estimated error rate.

Violations we noted of improper sampling procedures included a situation where a miner left his sampler running on the sidewalk for about 90 minutes before entering the mine. In another instance, a mine operator recorded, on the mine data card, that the sample was taken for 8 hours, but the sampler had actually been running for only 2 hours. In a third instance, the miner ran the sampler only when he was cutting coal--about 2 hours--however, the dust sample operator recorded, on the mine data card, that the sample was taken for 8 hours.

We believe that proper sampling practices were not always being followed by miners and mine operators because:

- Samples were selected and controlled by mine operators.
- MESA inspectors were generally unaware of the mines where samples were being taken and therefore could not routinely visit such mines to help insure that operators followed proper sampling practices.
- Miners do not like to wear cumbersome dust samplers and MESA has not been totally successful in helping miners understand the purpose of the program and the need for proper sampling procedures.
- MESA's training course for coal mine officials does not sufficiently explain sampling procedures or emphasize their importance.
- Fines for mine violations are nominal and often are not promptly collected.

Each of these matters is discussed in detail in the following sections of this report.

Samples selected and controlled by mine operators

MESA's sampling program did not provide adequate insurance that samples submitted by mine operators were statistically representative of the actual dust conditions. MESA inspectors generally do not know when samples will be taken

by mine operators and therefore seldom observe sampling practices and procedures. Although we could not demonstrate that operators attempted to obtain unrepresentative dust measurements, we noted (1) the opportunity for such actions and (2) indications that such actions may have been taken.

During our review MESA officials, in some cases, questioned the validity of samples submitted by mine operators and whether such samples represented actual mine conditions. MESA officials said exceptionally low dust levels indicate questionable sample results. For example, MESA officials told us concentrations of 0.1 milligram are possible under high moisture and effective ventilation conditions; however, other MESA officials said mine conditions of 0.1 milligram concentrations are highly unlikely. We noted that about 18 percent, or 3,050 of the 16,876 high-risk occupation samples submitted by 125 mines in the Mount Hope District from January 1, 1973, to March 31, 1974, had concentrations of 0.1 milligrams.

MESA officials identified several instances in which they felt the results of the samples were questionable. For example, in May 1974 MESA inspectors found that in two mines in the Mount Hope District, the dust levels exceeded the 2.0-milligram standard and cited the operators for violations. Samples taken during the same month and the following month submitted by the mine operators showed 20 of the 50 samples had dust level concentrations of only 0.1 milligram. MESA officials also questioned the validity of these results, and returned to the mines in July 1974 for additional samples. They found that dust levels still exceeded the minimum standard and again cited the mine operators for violations. In July and August, 40 samples were taken by the operators and 17 had 0.1 milligram concentrations. MESA inspectors again returned to the mines in October 1974, took samples, and cited the operators for violating the standards. During subsequent inspections made by MESA while the mine operator was continuously sampling and which was observed by the inspector, MESA found that correct sampling procedures were being followed and, as a result, the samples taken by the mine operator on that occasion had dust concentration results that were realistic.

In exploring the feasibility of getting samples with 0.1 milligram dust concentrations, accompanied by MESA inspectors, we took 12 individual samples during our visit to 14 of the 125 mines. In most cases, the samples were taken in mine areas other than the high-risk occupation areas, which, according to MESA officials, are the highest areas of dust concentrations. Our sample results showed dust levels from 0.2 to 2.0 milligrams. We also took 13 dust samples under

difficult conditions, such as office locations and outdoor areas. The dust level concentrations for 11 samples taken in office locations all exceeded 0.2 milligrams. The two samples taken outdoors measured 0.1 milligrams.

MESA inspection program
needs to be improved

The MESA inspection program should be improved so that inspectors can more often observe actual sampling procedures to help insure that mines are complying with established dust standards. MESA could not provide us information on the percentage of inspections on which inspectors observe sampling. However, during 1973 and 1974 Mount Hope District officials conducted 8,122 and 5,845 health related inspections respectively, but issued only 9 and 102 violation notices to operators for not following proper sampling procedures. During 1974, MESA made about 24,000 health and safety mine inspections nationwide and issued 274 violation notices to operators for using improper sampling procedures.

MESA officials said that very few violation notices are issued for not following proper sampling procedures because their inspectors seldom observe mine operators actually taking samples. Such inspections are not made because (1) it is difficult to determine when operators are conducting their sampling program under normal sampling cycles, (2) while information is available on which mine sections are required to sample continuously this has not been a MESA criteria used to determine when inspections should be conducted, and (3) in districts where inspectors take dust samples as part of their routine inspection, inspectors avoid going in sections when the mine operator is conducting his dust-sampling program.

Each year about 500,000 samples are taken at about 3,700 mines. Administratively, it may be difficult to determine which mines are taking samples under the normal cycle requirements which allow mine operators to select the days when they take dust samples. However, information on mines required to sample on a continuous basis is available in MESA subdistrict offices. Based on this information, MESA inspectors could schedule their visits to observe mine operators taking samples.

MESA selected the 14 mines which we inspected by noting those which had previously exceeded statutory dust standards and which were required to continuously take samples until the dust levels were reduced to the established standards. Because of the observations they made during our visits (see p. 16), MESA's inspectors issued violation notices to the operators of 5 of the 14 mines for not following proper sampling procedures. In addition, we observed improper sampling

procedures at the remaining 9 mines but the inspectors did not because they were in other areas of the mine at the time.

Under its revised health inspection procedures, which MESA began to initiate in September 1975, MESA said it will emphasize establishing proper respirable dust control measures rather than sampling by the inspectors. Operators are to develop plans for maintaining an average concentration of 2.0 milligrams or less. MESA will review and test the plans by taking dust samples. However, once the plan is approved, their inspectors will be required to visually, and through measurements of engineering parameters, evaluate the effectiveness of the plan by making sure that all its elements, such as proper ventilation, are followed. We were told that if MESA inspectors find that the plan is not being followed, they will take appropriate action by citing a notice of violation or issuing a closure order. MESA officials believe the new program will be more effective than the current program because

--individual inspections will require less time and more inspections can be made with the same number of personnel and

--inspectors can do a better job by spending less time sampling and more time inspecting.

We have reviewed the procedures in MESA's new program and we believe that, if properly implemented, they can help to improve dust levels.

Certain proper sampling procedures not emphasized in MESA training course

MESA's training course for mine officials to learn how to properly use dust sampling equipment and conduct sampling programs has not been as effective as it could be because major sampling procedures are not covered and/or emphasized. We sent a questionnaire to 167 mines in MESA's Mount Hope District. The questionnaire was addressed to the mine's health specialist who was asked to evaluate MESA's dust-sampling program and training program. The questionnaire showed that nearly half the respondents rated the course as fair, poor, or very poor.

We attended a training course and noted that the MESA instructors did not discuss several major sampling procedures. For example, there was no specific discussion concerning the requirement that samplers must be maintained within 3 feet of the miner, the requirement that air-flow rates must be

frequently checked, and that sampler elements should not be interchanged. Also, little emphasis was given to the cleaning and repairing of sampler parts and the care needed to be exercised in handling the samplers. Instead, attendees were furnished MESA circulars which described and emphasized proper sampling procedures and sampler maintenance. A MESA official said this practice is followed in all dust-sampling courses.

We believe that the results of our questionnaire, along with our limited observations of the MESA training program and our observations that proper sampling procedures were not being followed at the mines we visited, indicate that MESA should improve its training by emphasizing pertinent sampling procedures that must be followed.

Miners' attitudes and understanding of sampling program affect accuracy of samples

MESA's efforts in working with miners and mine union officials to help insure that miners understand and use proper sampling procedures have not, in our view, been highly effective. Miners dislike wearing dust samplers and their lack of understanding of proper sampling procedures that MESA has recommended contributed to inaccurate dust measurements.

Seventy-five of the 125 coal mine health specialists who answered our questionnaire stated that miners in some cases refused to wear the samplers. Eleven of 67 miners who we interviewed said that they did not like to wear the samplers. The reasons given for their objections were:

<u>Reasons</u>	<u>Number of responses (note a)</u>	
	<u>Health specialists</u>	<u>Miners</u>
Too noisy	40	4
Uncomfortable	47	4
Hazardous	38	4
Gets in the way of work	87	4
Does not do any good	50	5
Other	26	4

a/ Total responses exceeded number of questionnaires returned because more than one response was given to some questions.

MESA officials told us that some miners attempt to get low dust readings so they will not have to wear the sampler often. Two miners confirmed this in replying to our questionnaire.

Many miners do not seem to understand proper sampling procedures or the purpose of the dust-sampling program. We asked miners what the purpose of the sampling program was, and 13 said the dust samples would be used to determine if they were eligible for black lung benefits. One miner said he had tried to get high dust sample readings to help him get black lung benefits; five other miners said they did the same thing, but gave us no reasons for their actions.

Miners' responses to questions on the sampler operations indicated that many were not following proper sampling procedures. For example, on 3 questions concerning these procedures, 38 of the 251 responses showed that the miners were not operating samplers continuously from the time they entered the mine until they left it. Also, our discussions with several miners during our visits to the mines indicated that they did not fully understand the required sampling procedures nor the purpose of the dust-sampling program.

To help miners understand the dust-sampling program, MESA and NIOSH personnel visited all mine union locals in 1973 and explained the program to union members. MESA inspectors also explained the program to miners during health inspections but believe their efforts have had only limited success because many miners have not been contacted. MESA said it currently plans to expand its work in this area and added that during 1975, it will send a brochure to each miner explaining the purpose and importance of the dust sampling program.

MESA penalty assessments and collections
do not adequately deter violations of
dust provisions

The objective of assessing civil penalties is to maintain proper health and safety conditions for coal miners and to insure that the coal mining industry fully complies with existing Federal regulations. We believe penalty assessments and collections were not effective in deterring operators from violating mine safety and health provisions because during our review we found:

- Assessments, settlements, and collections were untimely.
- Penalties recommended by MESA assessors were substantially reduced by the Solicitor's and Hearings' Offices.
- Certain factors used by assessors to determine penalty amounts were not consistently applied.

--Some violations were not assessed or settled, and fines were not always collected.

The assessment and collection of penalties are discussed in detail in chapter 3.

DUST SAMPLING EQUIPMENT AND WEIGHING
OF DUST SAMPLES CONTRIBUTED
TO INACCURATE MEASUREMENTS

NBS reported that the dust-sampling equipment and procedures now being used provide a relatively large uncertainty in measuring coal dust levels in underground coal mines partially because of the complex and rugged mine environment. NBS also noted that the weighings made by MESA and the manufacturers contributed an unavoidable uncertainty to the overall error in dust concentrations. NBS further stated that weaknesses in MESA's program weighing procedures, which did not detect a weight loss of cassettes after they were manufactured, contributed to errors until this problem was detected and apparently solved early in 1975. Although both cassette manufacturers have stated that they have corrected their cassette weight loss problem and the Bendix Corporation, which had quality control problems, has taken action to correct these problems, NBS still believes that the dust-sampling equipment currently in use could be improved to provide more reliable results.

NBS estimated that when the samplers are operated by trained scientists using meticulous care, the equipment and weighing errors combined to yield dust level measurements which vary by ± 32 percent from actual dust concentrations.

Dust-sampling equipment
needs to be improved

NIOSH is responsible for approving the efficiency and accuracy of the dust sampling equipment and MESA is responsible for approving the equipment as being safe when used underground. To date, four personal dust samplers, which went through an evolutionary process of design and development, have been approved. From fiscal year 1970 through fiscal year 1975, MESA and BOM together expended over \$1.9 million for improving the dust-sampling equipment. The samplers are also used in areas of occupational dust sampling other than coal mines. According to NBS' analysis of research reports on the equipment's performance the sampler, when used in controlled laboratory conditions, produces reliable results. However, in underground mines, the equipment does not provide the same accuracy.

Dust sampling data collected in laboratories, with the approved samplers, vary about + 7 percent from the actual dust concentrations. NBS scientists said that in underground sampling, however, the physical impairments such as jarring the sampler and dynamic properties of the coal mine atmosphere are not adequately understood in terms of their effect on the accuracy of coal dust measurements. NBS said that such things as difficulty in making flow rate adjustments, air currents, and handling of the equipment by miners greatly increase the difficulty in obtaining accurate results. Also, NBS found that both Bendix and MSA cassettes, the latter to a lesser degree, lost weight after time which resulted in dust measurements being understated before corrective action was taken in 1975.

Experiments conducted by BOM and an independent coal association have shown that precision achieved by approved dust samplers when operated in controlled laboratory conditions is very difficult to realize in the field because of operating difficulties in the underground mine environment. These difficulties stem from problems in maintaining and adjusting the samplers under the constraints of the coal mine atmosphere. When several personal samplers were operated in an actual mine, with their inlets 3 to 6 inches apart, it was observed that they produced dust measurement values exhibiting much larger error rates than above ground. An evaluation of many different sets of field measurements revealed that these errors varied from 8 to 50 percent. The larger variations were obtained in the mine in spite of the fact that the samplers were carefully maintained and operated by relatively skilled and knowledgeable individuals. Preliminary results indicate that dust measurement errors are much worse when taken by miners under less controlled conditions. Under these conditions the error rate could be at least 50 percent.

We observed several instances where the handling of equipment could have caused improper sample results. For example, a miner was wearing a jacket which, at times, covered the sampler unit. This could have affected the dust concentration level. Another miner, wearing a sampler, was lying on a conveyor belt that was covered with coal dust. This could also have affected the measurement of the dust concentration.

In addition, the two samplers most frequently used by the miners--Mine Safety Appliances and Bendix--did not produce equivalent results. A 1974 preliminary report from BOM concluded that one sampler usually gives measurements about 20 percent higher than the other. It was later discovered that most of this difference was because Bendix cassettes lost weight during storage. In computing the amount of respirable coal dust in mines, the weights of empty dust filter cassettes (see app. V) assigned by the manufacturer

are compared to the weights of cassettes containing coal dust from mines. The difference is used to calculate the mine's dust concentration. Bendix attributed the weight loss in their cassette to the type of material used in manufacturing the cassette. During its weighing experiments conducted in late 1974 and early 1975, NBS reweighed cassettes which had been weighed by Bendix 6 weeks before and found that 85 percent of the cassettes were weighed within ± 0.1 milligram accuracy by the manufacturer. However, after 5 months, NBS again reweighed the cassettes and found that only about 8 percent of the cassettes fell within this limit.

On April 1, 1975, NIOSH at MESA's request held public hearings to discuss the further use of the Bendix cassettes. Results of MESA's studies agreed with NBS' evaluation. In May 1975, Bendix started manufacturing their cassette with a different type material which has been approved by NIOSH. MESA and Bendix believe this change should prevent unacceptable weight loss. In commenting on our report, MESA stated that it did not believe that MSA cassettes were losing weight, contrary to NBS' findings. We discussed this matter with MSA officials who subsequently reviewed the weight loss problem and in August 1975 told us that they concurred with NBS that its cassette lost weight. MSA officials attribute this weight discrepancy to a moisture problem and added that corrective action has been taken.

It should be pointed out that since the inception of the program several improvements in the accuracy of the equipment had been made. For example:

- pulsation damping devices were added to the samplers to improve sampling precision;
- a new, more rigid mounting bracket was approved for the MSA sampling head so that misalignment of the cyclone inlet will not be affected by physical impact;
- a new, lighter Bendix sampler was developed which gives an indication of how long the sampler was run; and
- NIOSH has developed revised performance requirements and prepared a proposed amendment to the existing Federal regulations to insure the quality of performance by the coal mine dust sampler unit.

NBS scientists concluded that greater accuracy could be achieved by additional improvements in the equipment such as flow rate regulators, alternate timing devices, more rugged components, and tamper-proof cassettes. The officials stated, however, that human errors in taking the samples could probably

not be eliminated. They indicated that either there should be further efforts toward improving the equipment, major re-design in equipment, or perhaps a new concept in sampling if the uncertainty in dust measurements is to be largely reduced.

Weighing of cassettes by PTSC and the manufacturers

NBS noted that PTSC and manufacturers' cassette weighings were not accurate before 1975 because:

- Bendix Corporation cassettes, which are used in over 40 percent of the samples, exhibited problems with quality control resulting in a large number of inaccurate weights being stamped on the cassettes.
- Both Bendix and MSA cassettes, the latter to a lesser degree, lost weight during storage.

MESA stated that Bendix has corrected both its material and quality control problems. NBS found, however, that an apparently unavoidable manufacturer and PTSC weighing error still exists.

MESA's specifications require that weights assigned to empty dust cassettes by manufacturers be within ± 0.1 milligrams of their actual weights. MESA tests the accuracy of the manufacturers assigned weights by requiring manufacturers to select at random and send to PTSC 10 cassettes from at least each day's production. PTSC then weighs the sample cassettes to verify the manufacturers assigned weight. If PTSC finds an error of more than ± 0.1 milligrams in any one of the cassettes, the manufacturer is instructed to reweigh all the cassettes from which the sample was taken.

The following table shows the results of PTSC's testing of the manufacturers assigned weights of cassettes from July 1973 through June 1974.

<u>Manufacturer</u>	<u>Number of sets submitted</u>	<u>Number of cassettes weighed</u>	<u>Number of unacceptable sets</u>	<u>Percent of unacceptable sets</u>	<u>Number of unacceptable cassettes</u>	<u>Percent of unacceptable cassettes</u>
Bendix	147	1,470	28	19.0	92	6.3
Mine safety appliances	227	2,270	13	5.7	15	0.7

As a result of the high rate of errors in the Bendix cassettes, PTSC evaluated Bendix's quality control procedures in March 1974 and reported that inaccurate weighings were caused by

- sensitive weighing equipment near heavy machinery;

- electrostatic charges on the filter cassettes,
- high air velocities within the weighing room,
- timing on the electronic automatic weight printer mechanism,
- use of only one workable balance, and
- insufficient number of employees to meet the production demands.

As a result of the PTSC staff visit, the following recommendations were made:

- Place cassette production lines away from manufacturing area.
- Maintain constant temperature and humidity.
- Investigate the stability of cassette material to determine if aging effects the cassette's weight.
- Design a lighter-weight, less static-prone filter capsule.
- Increase number of production personnel and obtain necessary additional equipment.

Because most of the recommendations were adopted, MESA stated that the manufacturer's rejection rate at PTSC decreased about 50 percent from July 1974 to December 1974.

To evaluate MESA's testing program, NBS obtained cassettes which were produced from March through July 1974, when MESA indicated that MSA and Bendix were experiencing a .7 and 6.3 percent rejection rate respectively on individual cassettes. NBS reweighed 202 MSA capsules and reported a rejection rate of 10 percent. A total of 50 Bendix capsules were initially weighed in 3 separate sets during August and September 1974. Based on the results of initial weighings the percentages of capsules in each set that would have been considered out of tolerance were 15, 71, and 100, when listed in order of increasing age. Bendix, which had taken corrective actions on some of its quality control problems as discussed above, was still experiencing a much higher rejection rate than MSA.

As previously indicated, both Bendix and MSA cassettes, the latter to a lesser degree, lost weight during storage. NBS believes that most of the difference between their weights and PTSC's was attributed to the weight loss factor. From its

reweighing experiments and from the recognition that the cassettes are subject to a moisture problem, NBS concluded, at that time, that further steps could be taken to improve MESA's testing and weighing program. Subsequently, PTSC has instituted a procedure to "bake" all cassettes before they are weighed to insure that volatile materials have been removed. PTSC believes the procedure should correct the weight loss problem.

To evaluate the accuracy of PTSC's weighing of cassettes filled with coal dust NBS, with the cooperation of NIOSH, filled 178 cassettes with coal dust of predetermined weights and sent them to PTSC for processing. From PTSC's weighing results, NBS concluded that the program weighing procedure yields a measurement uncertainty of about ± 7 percent. For example, one of the dust-filled cassettes weighed 2.2 milligrams at NBS but only 1.8 milligrams at PTSC which is a dust concentration difference of $+ .4$ milligrams. Of the cassettes that were preweighed by PTSC 46 percent differed by more than the acceptable variance of ± 5 percent from the NBS weighings. In addition to these differences, NBS noted that PTSC failed to recognize that the cassettes had been opened and resealed. This action, if detected, should have been the basis for rejection. MESA officials stated in commenting on our draft report, that they recognized this problem and have taken steps to develop a tamper-proof cassette.

NBS said that PTSC's written procedures are well designed and included necessary factors for accurate weighing. NBS scientists believe that even though there are slight inaccuracies in PTSC's weighing of field cassettes, the necessary steps to improve the weighings would only have a minimal effect and would not be feasible because of manpower and time constraints.

QUESTIONABLE METHODOLOGY FOR COMPILING COMPLIANCE STATISTICS

BOM's data processing center in Denver, Colorado (1) computes dust concentrations from sample data results provided by PTSC, (2) generates reports for MESA's health and safety offices, (3) reports on the number of mine operators in compliance with sampling requirements and dust standards, and (4) reports compliance statistics on the number of mine sections that meet the dust standards. We found, however, that MESA's report on the number of mine sections that are in compliance with existing standards was inaccurate to some extent because all dust samples were not used in the compilation.

In the past, MESA computed the number of mine sections that comply with the respirable dust standards by using only

the high-risk occupation samples submitted by the mine operators. Intake air samples, MESA's high-risk occupation samples, and face occupation samples, which included samples from those mines other than high-risk employed at the face of the mine section were not used. A report that MESA prepared for us showed that on December 16, 1974, 2,539 of 2,727 sections (93 percent) were in compliance with the 2.0-milligram dust standard, based on the high-risk occupation samples submitted by the operators. We found that 44 additional sections were in violation based on MESA samples or a reduction in the compliance rate to 92 percent. Information on air-intake violations was not readily available.

We believe all samples, including those taken by MESA inspectors and operator air intake samples for which violation notices are issued, should be considered in computing the number of mine sections that comply with dust standards. We discussed this matter with MESA officials in December 1974. In June 1975 MESA established a system to determine the percentage of sections that are in compliance. This was based on violations issued as a result of the mine operators' samples of high-risk occupations and intake air and MESA's samples of high-risk occupations, face occupations, and intake air. In addition, this system shows the percentage of sections that did not comply during the preceding month and during the current year-to-date. We believe that the new system will improve the statistics used to show the degree of compliance.

CONCLUSIONS

The Department of the Interior reported that 94 percent of the underground coal mine sections are within the statutory respirable dust concentration standard; however, we found that the dust-sampling program on which this conclusion was based contained discrepancies and uncertainties which made it difficult to accurately determine how many sections were complying.

The uncertainty and discrepancies in measurements primarily resulted from:

- Operators and miners not following proper sampling practices.
- Dust-sampling equipment not providing accurate measurements of dust concentrations, weight loss of cassettes, and inaccuracies in weighing dust cassettes.

Improvements have been made in reducing the levels of respirable dust in underground coal mines as a result of the Federal Coal Mine Health and Safety Act of 1969. Improvements

have been made, in part, by changes in the dust-sampling equipment as is clearly demonstrated by relatively recent modifications made in the equipment and the issuance of several contracts by BOM to further improve the equipment being used in the majority of underground mines throughout the country. Operators have implemented better and more ventilation and water spray methods to keep the respirable dust lower than it was before the Federal Coal Mine Health and Safety Act was enacted.

Considering the ultimate consequences of high levels of respirable coal dust in the mine atmosphere--coal mine workers' pneumoconiosis--and recognizing that since the enactment of the Federal Coal Mine Health and Safety Act of 1969 up to November 1975 about 1,000 coal workers have been x-rayed and diagnosed as having coal workers' pneumoconiosis, Federal agencies responsible for the administration of the Federal Coal Mine Health and Safety Act must continue their efforts to improve the mine-sampling equipment, the sampling procedures, and the training associated with these programs to insure, to the fullest possible degree, that respirable coal dust in underground mines, in line with the intent and objectives of the Congress as evidenced by the passage of the Federal Coal Mine Health and Safety Act, does not exceed that of a healthy environment.

Recognizing that there is and will continue to be an increasing need to further expand coal production in this country, it is incumbent upon the Secretary of the Interior to insure that the provisions of the Federal Coal Mine Health and Safety Act are effectively carried out and that all operating sections of the Nation's coal producing mines attain levels of respirable coal dust at, or below, the statutory maximum.

Although MESA has informed us that the cassette weight loss problem has been corrected, the uncertainty of the equipments' accuracy in the mine environment, the effect of operators and miners taking the samples rather than experienced research personnel using meticulous care, operators and miners not following proper sampling procedures, and slightly inaccurate weighing of field cassettes at PTSQ, make, in our view, current dust measurements questionable.

RECOMMENDATIONS

We recommend that the Secretary of the Interior and the Secretary of HEW initiate action to further improve the dust-sampling equipment which includes recommendations made in the NBS report, such as flow rate regulators, alternate timing devices, more rugged components and tamper-proof cassettes.

We recommend also that the Secretary of the Interior instruct MESA and BOM and the Secretary of HEW instruct NIOSH to conduct a joint study to determine quantitatively the accuracy and reliability of dust measurements when taken with the current equipment by coal miners in underground mines. We suggest that the assistance of the equipment manufacturers and NBS be solicited in this study.

We further recommend that, based on the results of such study, Interior and HEW determine what changes should be made in the dust-sampling program to help insure greater compliance with the legislative intent. The Secretary of the Interior and the Secretary of HEW should then require that MESA and NIOSH take appropriate corrective action.

Also, we recommend that the Secretary of the Interior instruct MESA to take the following actions to help insure operators and miners follow proper sample practices:

- Develop procedures which would require operators to notify MESA when samples will be taken so that it can consider using this information in scheduling mine visits.
- Discuss proper sampling procedures in more detail during training sessions for mine officials, and work with United Mine Workers of America and coal mine officials to help miners understand the purpose of the dust-sampling program and the need to follow proper sampling procedures.

AGENCY AND MANUFACTURERS' COMMENTS AND OUR EVALUATION

We obtained oral and informal written comments from the Departments of the Interior and HEW and from Bendix Corporation and the Mine Safety Appliances Company.

Department of the Interior

Interior officials stated that they are aware that their dust-sampling program has certain limitations. They stated, however, that the current dust-sampling program was primarily designed to reduce the respirable dust levels in coal mines and to show the direction and general magnitude of that reduction. The officials stated that the program has sharply reduced the dust levels and the compliance rate has been established, to a sufficiently accurate degree, to measure the success of the program. They further stated that their dust-sampling program uses the best available equipment.

We recognize that it is generally agreed by miners, mine operators, and union officials that a significant reduction in the respirable dust levels in coal mines has been achieved. We also recognize that the Department of the Interior has, through BOM and MESA, made many improvements in the program and equipment. We believe, however, that certain additional improvements such as flow rate regulators, alternate timing devices, more rugged components, and tamper-proof cassettes are warranted and can be made to obtain more accurate dust measurements.

As we previously stated, we have not made an analysis of the appropriateness of the 2.0-milligram respirable dust standard. We noted, however, that the standard was established after considerable deliberation and was based on the best available evidence which showed that if respirable coal dust is limited to this level, pneumonconiosis should be prevented. Accordingly, we believe that the program should, to the greatest extent possible, monitor dust concentrations with the highest degree of accuracy possible to help insure that established levels are being met. We believe further that essential improvements would help to provide fair and equitable treatment of mine operators who are cited for violations of the dust level standards.

MESA contended that the sampling equipment has a maximum potential variation of about ± 7 percent per cubic meter of air for 10 samples which is only about one-fifth as much as NBS' estimated variation when miners are taking the samples. NBS based its estimate on its own research and studies made by Federal and private associations within the coal industry who have performed research on the dust equipment. They also reviewed a considerable amount of study and research results that pertained to the equipment. MESA could not provide sufficient evidence to NBS to demonstrate that the dust-sampling equipment and program is as accurate and reliable as it claims.

MESA officials told us that they conduct about 500 investigations of unsigned dust data cards each month to determine whether mine operators are following proper sampling procedures, and have issued violation notices when the prescribed procedures were not followed. These officials added that they are currently investigating over 1,800 irregularities in mine-sampling procedures for possible criminal action. In addition, MESA officials asked if our findings are a valid basis for criticizing their program because of our limited number of actual mine visits.

We recognize that the number of visits we made to mines to observe operator sampling was limited for practical reasons. However, we believe that our observations are a valid basis for criticism because (1) MESA selected the mines,

(2) mine operators were informed of the purpose of our visits, (3) the Mount Hope District, according to MESA, is representative of the dust-sampling program, and (4) the number of procedural errors were numerous and were noted in every mine we visited.

We recognize that MESA's inspection program helped prevent and/or corrected many dust-sampling violations. However, on the basis of the results of our review, during which time we actually observed mine operators taking samples, and based also upon MESA's statements that they frequently cite operators for improper practices while dust samples are taken, we believe that MESA can further improve its program to detect improper sampling practices. In this regard, we believe that MESA should, to the extent possible, have its inspectors consider using information developed by mine operators which would inform MESA as to when the operators expect to take dust samples. In this way, MESA inspectors could schedule their required visits at these times, which would maximize the effectiveness of the MESA inspections by detecting weaknesses, such as those which we noted during our visits, but which otherwise may go undetected.

In commenting on our recommendation that the Secretary of the Interior and the Secretary of HEW initiate a joint study to determine quantitatively the accuracy and reliability of dust measurements when taken with the current equipment by coal miners in underground mines, Interior officials believed that such a study would be beneficial to the program.

In commenting on our recommendation that mine operators notify MESA when they plan to take samples, MESA officials stated that requiring mine operators to notify them is, in their opinion, a violation of the Federal Coal Mine Health and Safety Act which states that "no advance notice of an inspection shall be provided to any person." We believe, however, that this notification does not constitute an advance notice of when MESA actually plans to visit the mines. MESA has the prerogative to make an inspection on any day--not necessarily on a sampling day the mine operators have chosen. Under the present procedures, mine operators take vastly greater numbers of samples than the number of inspections that are currently required to be made by the MESA inspectors. MESA determines the specific dates--a minimum of four times a year--when they will actually visit the mine. We believe that having readily available information on the mine operator's sampling schedule will provide MESA with information to further improve its inspection program.

MESA pointed out, in commenting on its training program, that the first session of the course "Sampling and Evaluation of Respirable Coal Mine Dust" was presented in February 1970

and since that time over 6,000 persons have received training. We were also advised by MESA officials that during the summer of 1973, MESA and NIOSH personnel met with the United Mine Workers of America district and local committeemen to discuss the dust-sampling program. MESA officials said the average attendance at the meetings was less than one-half of those that were supposed to be present. However, they added that more than 1,500 persons did attend.

MESA officials said they believe that miners who were in the mines before 1970 have been adequately advised of the purpose of the dust-sampling program but admitted that new miners, many of whom had been hired during the last few years, may not be as cognizant of the reasons and requirements of the program. MESA, according to its officials, is continuing its efforts in this regard and added that although their health specialists visited all mine union local offices in 1973 to explain the program to union members, their efforts have had only limited success because a sufficient number of miners were not contacted. MESA officials said that in expanding their work in this area during 1975, they plan to send a brochure to each miner explaining the purpose and importance of the dust-sampling program and added if this effort is successful, they will follow up with additional brochures.

We believe that the response that we obtained from mine operators and the miners show that a need exists for improvements in MESA's training program. In a MESA survey of mine operators completed in December 1974, the response from one MESA district showed that the sampling program was being conducted by qualified persons in 92 percent of the mines; however, the same survey showed that in 80 percent of these mines the air-flow rate was not checked during the first hour of operation, as is recommended by MESA procedures.

MESA has made extensive efforts to train mine operators and miners in proper sampling techniques and the basic purpose of the program; however, we believe that additional improvements are warranted. In continuing its efforts to further improve its training program, and adequately inform mine operators and miners of the importance of the dust-sampling program as well as the proper use of dust-sampling equipment, we believe that MESA should insure that all major aspects of the program, such as the placement of samplers, checking of air-flow rates, and connection of sampler elements are emphasized in training sessions.

Department of Health, Education,
and Welfare

In commenting on our report, NIOSH officials stated that no one disagrees with the fact that problems have been and

are being encountered in the monitoring of coal mine dust levels. However, many corrective actions have already been taken, such as adding pulsation dampeners to the dust-sampling equipment, increasing the strength of the head to filter holder assembly, and correcting a cassette weight loss problem with the Bendix cassettes.

Concerning the weighing of cassettes, NIOSH generally agreed with NBS' findings. Concerning the equipment, they said that it is among the most accurate and simple to operate for its purpose and additional improvements may not be technically or financially possible at the present. They believe the personal samplers as they exist today are technically adequate. However, in measuring coal mine dust levels, the sampler must be used correctly. This they stated, becomes a factor of proper training and conscientious use of the device by the coal miners. They further stated that using area sampling to verify personal samples taken should be considered as a possible mechanism to increase confidence in personal sampling results.

While we generally concur with NIOSH's comments, we believe, along with NBS, that certain improvements can be made to the equipment such as flow rate regulators, alternate timing devices, more rugged components, and tamper-proof cassettes. In addition, we concur with NIOSH's observation that to provide accurate results, the sampler must be operated correctly which requires proper training and conscientious use. Improvements in this area also can further improve the accuracy of the equipment and resulting samples.

NIOSH officials generally agreed with our recommendations. They added that some improvements have been initiated regarding more rugged construction and improved air-flow rate of the dust sampler.

Bendix Corporation

In commenting on our report, Bendix officials generally agreed with our findings. They stated

"The basis of the dust sampler program has been and presently is to develop and maintain an accurate means of collecting and recording concentrations of respirable dust in coal mines. To accomplish this objective, it was necessary to design and develop appropriate equipment, including a cassette capable of measuring concentrations of respirable dust to a very high degree of accuracy (+ or - one tenth of a milligram). Such high degrees of accuracy are indeed much more compatible to a laboratory environment than that of a coal mine. Such a cassette had to be

constructed so that it could withstand the rigors of one of the most rugged industrial environments that exist today, namely the work area of a coal mine. We are unable to find a comparable situation existing in any other industry."

The officials further stated that

"* * * when the program was initiated in 1969, there was a limited body of knowledge in this country, concerning the development and use of coal mine dust personal sampler equipment. As knowledge of the problems and the state of the art advanced, so also the equipment and procedures utilized in the program have improved. Although the dust sampling program has been criticized in many quarters and indeed all of us recognize there is an ever present need for improvement, one should not lose sight of the fact that the program has accomplished its basic objective of improving the environment in the coal mine. In a short period of time there has been made vast improvements and this has been accomplished from a point where little or no activity had transpired before. Today, the air in coal mines has substantially improved and by continuation and improvement of the dust sampling program, we believe the coal mines will become an even healthier environment."

In addition, the Bendix officials stated that

"* * * limiting characteristics of a product may or may not be the responsibility of a manufacturer. When such limitations arise because knowledge in the field or the state of the art has not sufficiently advanced to a point where the limitations can be overcome, no such responsibility can reasonably be imputed to the manufacturer. * * * the shelf life problem, an obvious product limitation, existed because appropriate polypropylene did not exist at the time the units were designed and developed, and approved by the Government. Further, the Code of Federal Regulations 30 CFR 74 did not contain a shelf life criteria, nor does such criteria exist in the Code today."

We generally concur with Bendix's comments. NIOSH officials told us that Bendix conformed to 30 CFR 74.3 (2ii) pertaining to the cassette capsule's composition when the

standard was first implemented. The officials added that the present acceptable material was not available at the dust-sampling program's inception. At the present time NIOSH is in the process of writing new standards regarding the dust equipment which will include a change in the capsule material in order to insure a longer shelf life.

Mine Safety Appliances Company

Generally, MSA officials agreed with our findings. Concerning the dust-sampling equipment, they said

"* * * the design of the MSA Gravimetric Dust Sampler utilizing the impingement of particulate on a membrane filter and resultant weighing of the filter, is the best method in the current state of the art for a personal sampler. We acknowledge that the item can be misused by untrained personnel and that tampering can be done both at the test site and at subsequent weighing.

"In summary, we feel that the MSA Sampler as designed and within the economic brackets required for putting these on individual miners, performs a satisfactory function."

Concerning cassette weight loss, they said

"MSA has investigated the reported loss of weight of Gravimetric Sampler filter capsules and has found that small changes in weight either positive or negative can occur if the filter capsules have come to equilibrium with different relative humidities between weighings."

"* * * Samplings of capsules made several months, and in some cases years, prior to the date of the study were weighed and the results compared with the original weights. Small losses in weight, for the most part within the allowed tolerance, were found. These capsules were then subjected to 100% RH for a period of 64 hours and regained the weight loss.

"The weight loss reported by the NBS was of the same magnitude as that found to be the effect of R.H. of the atmosphere with which the capsule is brought into equilibrium. Since, in use the collected dust sample can also pick up water, the filters should always be weighed dry. MSA has

therefore instituted a drying step just prior to determining the tare weight in the manufacturing procedure."

CHAPTER 3

PENALTY ASSESSMENT AND COLLECTION

PROCEDURES NEED TO BE IMPROVED

Civil penalties are assessed by the Federal Government to help insure that coal mine operators comply with existing health and safety standards. As we have found several times in the past, Interior's procedures in assessing and collecting penalties needed to be improved because:

- Penalty assessments, settlements, and collections were untimely.
- Penalties paid were much lower than the amounts originally assessed and were a questionable deterrent to noncompliance.
- Factors used to determine penalty amounts were inconsistently applied.
- MESA could not insure that all violations were assessed, settled and/or collected.

MESA again revised penalty assessment, settlement, and collection procedures for all coal mine health and safety violations. These procedures were published in the Federal Register on May 7, 1974, and became effective August 1, 1974. We made a limited review of the new procedures, and if they are properly implemented, believe they should result in more timely collections and should help insure that all violations are assessed, settled and the fines are collected.

We question whether the August 1974 procedures providing for more consistent assessments because the Office of Assessment has been reorganized, will attain these results because of the subjectivity involved in determining the gravity of the violation. In addition, we question whether the amounts of the fines, which will be less because the penalty assessed will be based on a smaller penalty amount which was the result of reductions made at the Office of the Solicitor and Office of Hearings and Appeals during the interim procedures, will further deter noncompliance.

TIMELINESS AND AMOUNTS OF ASSESSMENTS AND COLLECTIONS

Interior officials, responsible for administering MESA's assessment and collection program, stated that the interim penalty assessment and collection procedures which were in

effect until August 1974, did not effectively deter operators from violating dust standards primarily because the amount of the fines were insignificant when compared to the cost of not being allowed to produce coal; were not collected promptly; and in some cases, were not collected at all. Coal mine operators we contacted during our review concurred.

For the 55 mines 1/ we selected for review, MESA had issued 456 notices to operators for violating respirable dust standards between January 1, 1973, and March 31, 1974. As of August 1, 1974, MESA had assessed penalties for 333 of the violation notices. It took MESA an average of 149 days from the date of abatement (correction) of the violations to assess the penalty for each of the 327 2/ violations. By November 1974, Interior had settled 83 violations and collected fines for 74. MESA officials stated that the fines were not collected promptly primarily because (1) the penalties were higher than the operators were willing to pay and were contested and (2) MESA did not have sufficient personnel to handle the workload.

For the 83 settled violations, the average assessed penalty of \$200 was reduced by the Solicitor to \$70, a reduction of 65 percent. The penalty finally decided upon by the Solicitor's Office takes into consideration factors such as the amount of evidence to support the case.

Penalty amounts decided upon by the Office of Hearings and Appeals were much lower than the penalties recommended by MESA. The Hearings Office sets penalty amounts after hearing from the mine operators and Federal Government representatives.

According to Interior officials, the Office of Assessment revised procedures which became effective August 1, 1974, will result in more timely and consistent assessments of the vastly increased number of violations cited. This is because (1) the initial assessments will be based upon more complete factual data than previous assessments, (2) initial assessments will more accurately reflect the amounts that had been collected in the past, and (3) there will be little or no incentive for the operators to pursue costly delays in further litigation of the issues. MESA said, however, that it has not analyzed what effect reduced penalty amounts will have on operators' compliance.

1/ We selected 55 of the 125 mines discussed on page 14 for a detailed analysis of the assessment and settlement of penalties for dust sampling and dust concentration violations.

2/ We eliminated six violations from our analysis because of incorrect dates recorded in assessment files.

We believe that MESA's revised assessment and collection procedures may aid in obtaining timely collections because the procedures are designed to inform the operator of the fine sooner. However, we question whether the amounts assessed will more effectively deter noncompliance of health and safety standards because the amount assessed will be less than that assessed under the interim procedures. The assessments will be based on a smaller penalty amount which was the result of reductions made at the Office of the Solicitor and the Office of Hearings and Appeals.

INCONSISTENT APPLICATION OF ASSESSMENT FACTORS

Our sample of 55 mines showed inconsistent application of assessment factors by MESA, such as whether the violation is "serious" or "nonserious" and often resulted in different penalties for similar violations. We found inconsistencies in the application of the assessment factors to be greatest in determining the gravity of the violations. MESA judged the gravity of the situation by using the following criteria:

Gravity

- Nonserious means a condition or practice which is not reasonably expected to cause injury.
- Serious means a condition or practice which is reasonably expected to cause injury.

Before August 1974, MESA's instruction procedures were not, in our view, sufficiently clear to permit assessors to uniformly interpret similar violations. A violation reviewed by one assessor as nonserious but by another as serious could result in a penalty assessment of one-half as much for the nonserious case. Violations, we believe, would be subject to less variance in interpretation if MESA developed more specific, detailed instructions. In this regard, the actual level of dust concentration may serve as a standard to help determine the seriousness of dust violations. No such instructions were included in the 1974 procedures.

Of the 333 violations noted in our sample, 99 were for the mine operators' failure to submit individual dust samples. Twenty-eight of these were considered serious while 71 were considered nonserious. Illustrations of statements provided by assessors relative to the gravity of the situation included:

Assessor A

"The failure to submit the required respirable dust samples does not indicate a hazard; however, it is

difficult to ascertain that the dust level is below the maximum allowable level without samples. For lack of evidence to the contrary, it is found the violation is nonserious."

Assessor B

"Unless the operator takes the required samples, he is unable to determine the concentration of respirable dust, which could be excessive, in the atmosphere of his employees. Prolonged exposure to high concentrations of respirable dust may lead to pneumoconiosis in those persons so exposed. Based on the foregoing facts, it is found that the violation was serious."

Although we found inconsistencies in some assessors' determination of gravity, we found that most of the other factors used by assessors were applied consistently. For example, during our review we found consistency in the application of good faith on the part of the mine operator in correcting the violation.

Assessor A

The operator abated the violation within the time required by the inspector. Based on the foregoing fact, it is found that the operator demonstrated good faith by normal compliance.

Assessor B

The operator abated the violation within the time originally fixed by the inspector. Based on foregoing fact, it is found that the operator demonstrated good faith by normal compliance.

We fully recognize that a number of factors can ultimately affect an assessor's final determination relative to the gravity or seriousness of the violation. However, as is clearly shown by the above information, an identical act--the failure of the operator to submit required dust samples--has been viewed differently by two assessors. It is on these types of violations that we believe MESA can provide additional guidance to its assessors to help insure more uniformity in assessing penalties.

Also, under the interim procedures, we noted that a simple violation was assessed twice by the same office. One assessor said it demonstrated ordinary negligence while another said it demonstrated gross negligence. One assessor established a fine of \$225 and the other set the fine at \$450 for the same violation.

During our review, Interior officials stated that penalties assessed under the new procedures will not be subject to the wide fluctuations they were under the earlier procedures because the fine assessed will be based on more realistic penalty amounts than in the past, functions are located in a central office, and a new formula to compute the amount of the penalties has been established which has an additive rather than a multiplicative effect on the penalty. We believe, however, that the new criteria can be further clarified to help prevent inconsistent assessments for similar dust violations if standards such as the actual level of dust concentration can be used to determine the gravity of violations.

MANAGEMENT CONTROLS OVER VIOLATIONS

At the time of our review, MESA did not have an information system to insure that all violations were assessed and once assessed were collected. Some violations were assessed twice and others should not have been assessed at all.

We noted that there was no pertinent information on 35 of the 456 violations in assessment office files such as when the violation was abated and what MESA's assessed penalty was although the violations had been corrected from 8 to as many as 466 days before that date. We found three violation notices that should not have been cited because no violation occurred. However, assessments were made. We also found three violations for \$154, \$45, and \$225 that were assessed twice.

MESA mailed 333 assessed violations to the Solicitor's Office in Arlington, Virginia, 44 of which were not recorded. The Solicitor's Office did not know whether it had received a notice of the violation because a system for reconciling violations received with those mailed to the office by assessment offices had not been established during the time of our review. In March 1975, the Solicitor's Office initiated a followup system whereby violation notices sent out from the assessment conference offices were checked with those logged in at the Solicitor's Office.

In early 1975 MESA implemented a revised numbering system to insure that all violations would be assessed and collected. According to a MESA official, this numbering system will be part of a computerized information system that will track each violation through assessment, settlement, hearings, and collection. The computerized system is not expected to be implemented until mid-1976.

CONCLUSIONS

In two earlier reviews (1972 and 1973) of the penalty assessment and collection program, we noted a need for (1) management controls to insure timely processing and collection of fines and (2) guidelines for a systematic and objective application of penalty assessments. While MESA's interim procedures appeared to be an improvement they were not effective and, at the time of our review over 2 years later, further changes were needed because:

- Penalty assessments, settlements, and collections under the interim procedures were still untimely.
- Recommended penalties were being substantially reduced by the Solicitor's and Hearings Offices and as a result were a questionable deterrent to noncompliance.
- Management controls were inadequate to insure that violations were assessed, settled, and collected.
- Criteria established for applying assessment factors were not consistently applied.

Neither we nor MESA have evaluated the effect of MESA's new assessment procedures; MESA officials however, stated that they should result in a more effective deterrent of noncompliance because fines are being assessed sooner and are made readily identifiable with the violation. MESA stated also that collections are more timely because operators are allowed to meet with assessors in the field to settle disagreements on recommended penalties.

The officials also said that when the new computerized information system is implemented it will provide MESA with controls to insure that penalties are assessed and collected on time for all valid violations.

We made a limited review of the procedures and, if properly implemented, believe that they should result in more timely collections and should help to insure that all violations are assessed, settled and/or collected.

Our review of the new procedures, including conference manuals that MESA developed to insure uniformity of assessments showed, however, that very little or no change has been made to help the assessor determine the gravity of the situation. Also, we question whether lowering fines will help to deter noncompliance. MESA made the reductions without making an appropriate evaluation to determine the potential effect on compliance.

RECOMMENDATIONS

We recommend that the Secretary of the Interior instruct MESA to:

- Clarify the newly defined assessment factors to help insure a more uniform application of the factors for the same or identical violations.
- Evaluate the penalty assessment program and ascertain what penalties will best serve to deter mine violations. Such study should be directed to determining what amount of fine is the most effective to help insure that mandatory health and safety standards are being met. It should also be determined whether other or additional measures, such as the issuance of closure orders in cases where serious recurring violations are detected, should be established. Based on this study, appropriate revisions to the penalty schedules and provisions should be made to help deter violations.

AGENCY COMMENTS AND OUR EVALUATION

MESA officials stated that application of the completely revised assessment procedures, which were established on August 1, 1974, will insure greater uniformity of assessments. They added that the new formula is detailed and more precise than the interim procedures were and will provide for more tightly controlled assessments. Based on our review of the new procedures we question, however, whether the new procedures will result in sufficient uniformity in assessments because the instructions to assessors are not sufficiently clear.

Concerning the reduction in the levels of penalties which we question because of the effect such reduction may have in helping to promote compliance with health and safety standards, MESA officials pointed out that the initial assessments are based on more complete and factual data than under the previous procedures and also the initial assessments will more accurately reflect what the administrative law judges have determined to be the proper amount to encourage and insure compliance with health and safety standards.

We concur with MESA's objective of basing initial assessments on complete factual data and if such data warrants a reduction in the assessments then such adjustments should be made. However, we do not believe that MESA should adopt a general policy of substantially reducing initial assessments because, under the interim procedures, the administrative law judges had often reduced the level of penalties MESA

recommended. During the quasi-judicial process mine operators and the Federal Government usually provide additional relevant data which is evaluated by the judges in arriving at a final determination of the penalty.

Furthermore, during our review several MESA officials told us that the low level of fines under the interim procedures was not an effective deterrent to noncompliance. Notwithstanding the specific level of fines that are assessed against coal mine operators, of greater concern is whether the health and safety conditions of the underground mines are being improved or promptly corrected in cases where violations are detected. It is primarily for this reason, that we believe the Secretary should instruct MESA to review the penalty assessment program to ascertain whether the present large reduction in initial assessments by MESA are contributing to better safety and health conditions of the mines or to a deterioration of conditions.

JERRY RUBIN, W. VA.
 EDWARD M. BELL, R.I.
 EDWARD M. KENNEDY, MASS.
 GASTON M. NEASE, WIS.
 WALTER P. MURPHY, MINN.
 THOMAS P. SALTON, MO.
 ALAN CRONIN, CALIF.
 MARK D. BURNES, IOWA
 WILLIAM D. BATHURST, MAINE

JACOB K. JAVITS
 PETER H. DOMINICK
 RICHARD S. SCHWEI
 ROBERT TAYLOR, JR., D.
 J. GLENN RYAN, JR.
 ROBERT T. STAFFORD, VT.

MARIO T. NOTO, STAFF DIRECTOR
 ROBERT E. HAGLE, GENERAL COUNSEL

United States Senate

COMMITTEE ON
 LABOR AND PUBLIC WELFARE
 WASHINGTON, D.C. 20510

B-170686

March 12, 1974

The Honorable Elmer B. Staats
 Comptroller General of the United States
 General Accounting Office Building
 441 G Street
 Washington, D. C. 20548

Dear Mr. Staats:

In 1969, Congress enacted the Federal Coal Mine Health and Safety Act, including provisions to ensure a speedy reduction in the levels of respirable coal dust in the Nation's coal mines. It is respirable coal dust which is responsible for the development of coal workers' pneumoconiosis, a disabling respiratory disease unique to coal mining.

The incidence of the disease is great. It has increased over the past two decades because of new mining techniques designed to extract greater quantities of coal from below the earth's surface. With this greater extraction of coal comes a greater profusion of respirable coal dust.

The Department of the Interior, which is responsible for administration of that legislation, reports that 90% of the operating sections of the Nation's coal mines have the level of respirable coal dust below the statutory maximum. I, for one, am greatly encouraged if, in fact, these reports are accurate. However, with the energy crisis now facing the Nation, there is and will continue to be an ever-increasing need to extract even greater quantities of coal from the earth. I am greatly concerned that in fulfilling this need, miners will once again be subjected to levels of respirable coal dust which exceed the demands of a healthy environment. To ensure that the reports of the Department of the Interior are accurate, it is necessary to determine the validity of the respirable coal dust sampling procedures. I would greatly appreciate it if you could provide this Committee with the necessary assistance in making this determination by undertaking an analysis of the dust sampling program.

BEST DOCUMENT AVAILABLE

The Honorable Elmer B. Staats
March 12, 1974
Page 2.

The staff of the Subcommittee on Labor stands ready to provide any necessary assistance and guidance to your staff in this matter.

I look forward to your early response.

With best wishes,

Sincerely,

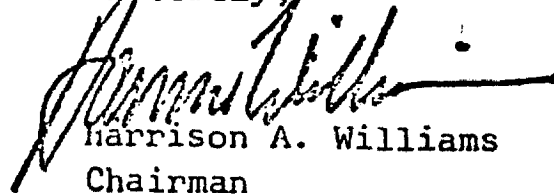

Harrison A. Williams
Chairman

HAW:gfa

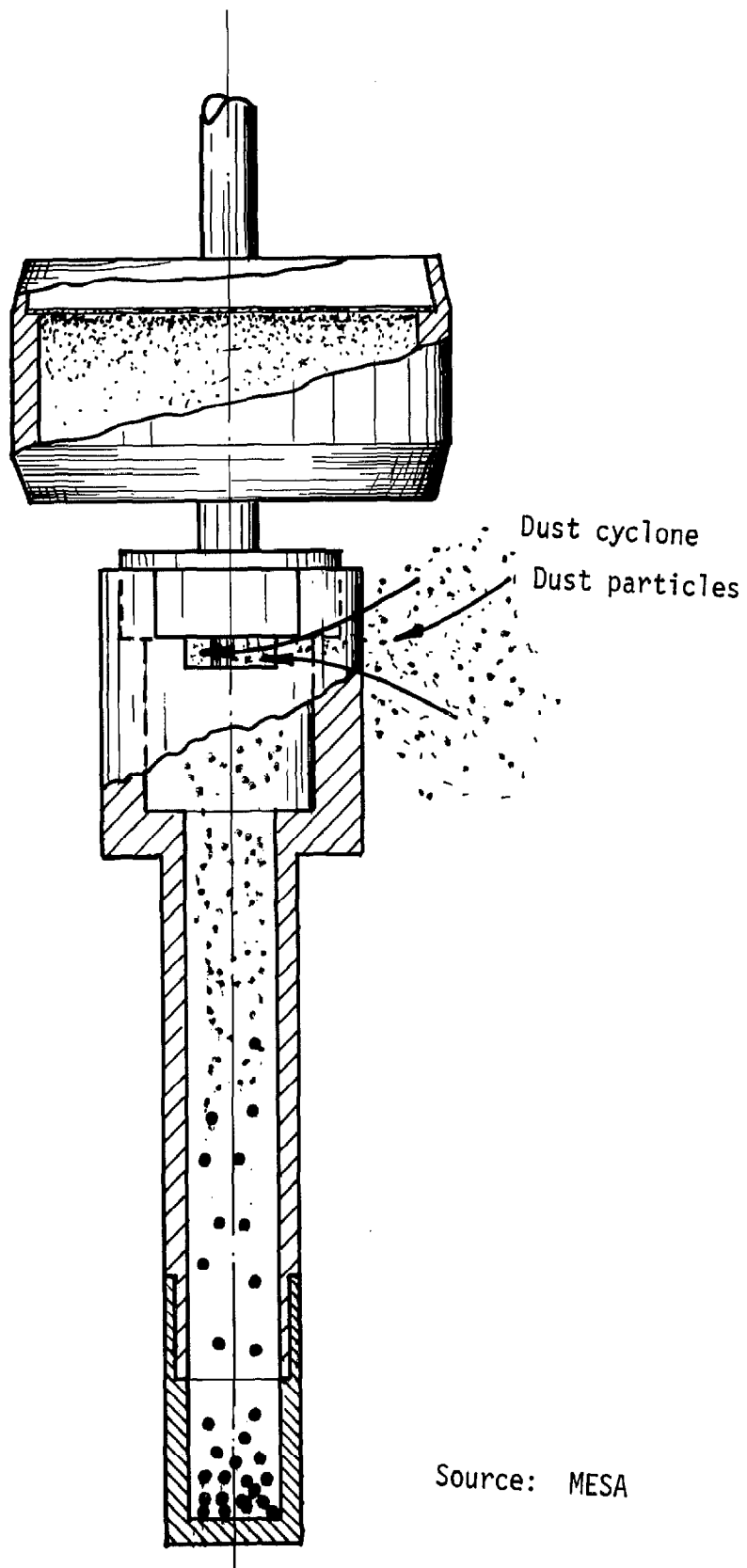

PERSONAL DUST SAMPLER

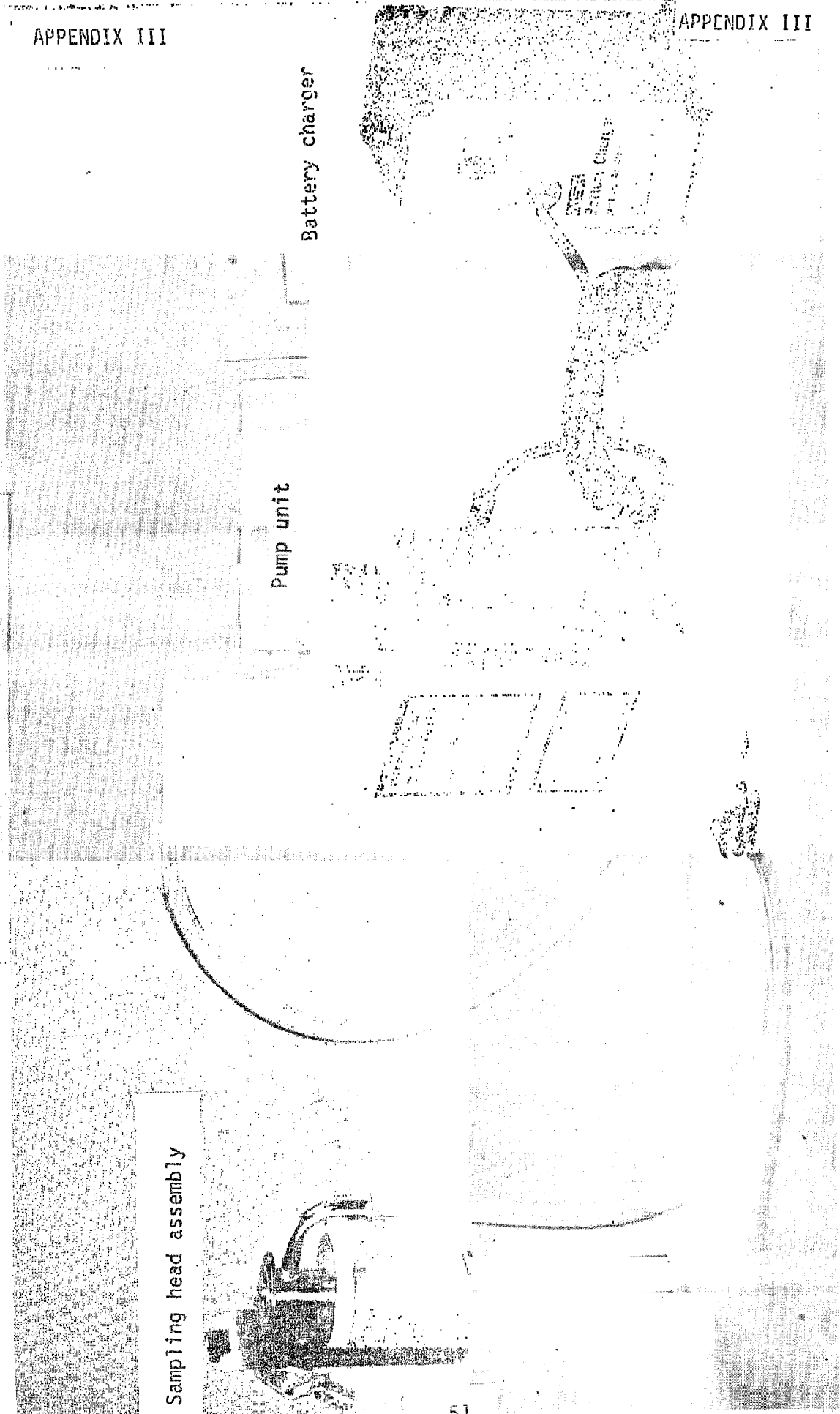

Sampling head assembly

Pump unit

Battery charger

MINE DATA CARD

CASSETTE NO. 40249991

INITIAL WT. _____

MINE ID NO. _____

FINAL WT. _____

SECTION ID NO. _____

SAMPLING TIME (MIN.) _____

MINER'S SSA NO. _____

OCCUPATION _____ TONS THIS SHIFT _____
TYPE OF SAMPLE

HIGH RISK _____ INTAKE AIR _____
NON-HIGH RISK:

FACE _____ NON-FACE _____ 203(B)(1) _____
FACE VENTILATION

EXHAUST _____ BLOWING _____

AUXILIARY _____ BRATTICE _____
TYPE OF MINING

DEVELOPMENT _____ RETREAT _____
METHOD OF MINING

CONTINUOUS _____ CONVENTIONAL _____

LONGWALL _____ OTHER _____

_____ CHECK IF SECTION WILL CLOSE
BEFORE NEXT SAMPLING CYCLE.

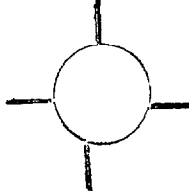

SIGNATURE:
(MINER SAMPLED) _____

(MINE OFFICIAL) _____

DATE _____

APPENDIX V

Faint, illegible text or markings, possibly bleed-through from the reverse side of the page.



USA 01001

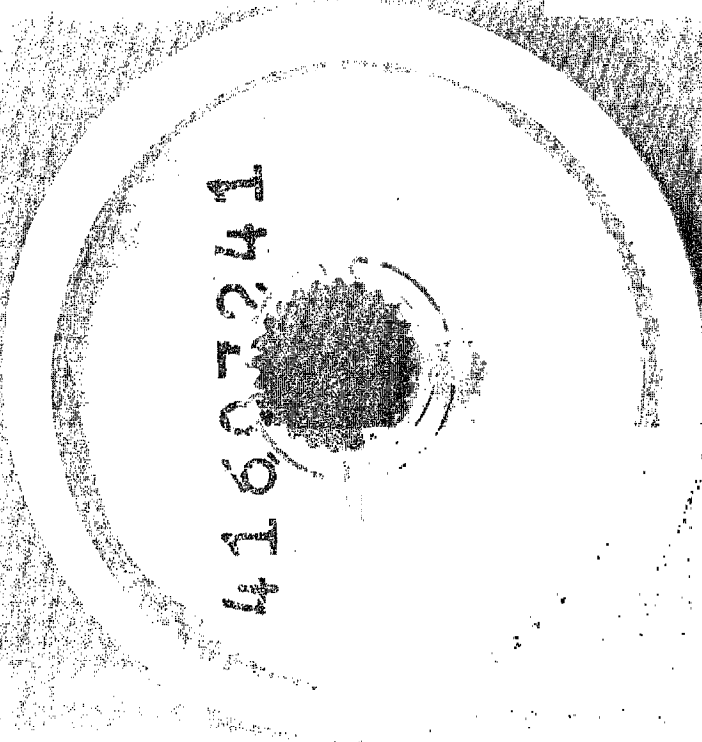

cassette